

65 th ENG
SMALL EMPLACEMENT EXCAVATOR
SEE
UNIT / MAINTENANCE
STUDENT HANDOUT

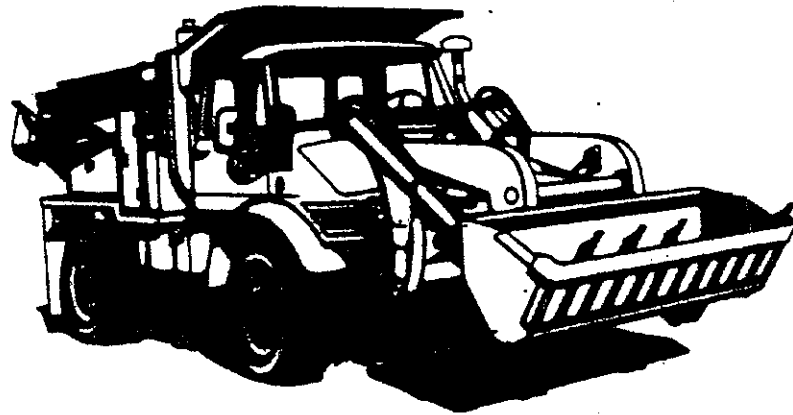

Prepared by:
NEW EQUIPMENT TRAINING BRANCH
US ARMY TANK -AUTOMOTIV -ARMAMENTS COMMAND
Warren, Michigan 48397-5000

JULY 1996

APPENDIX A



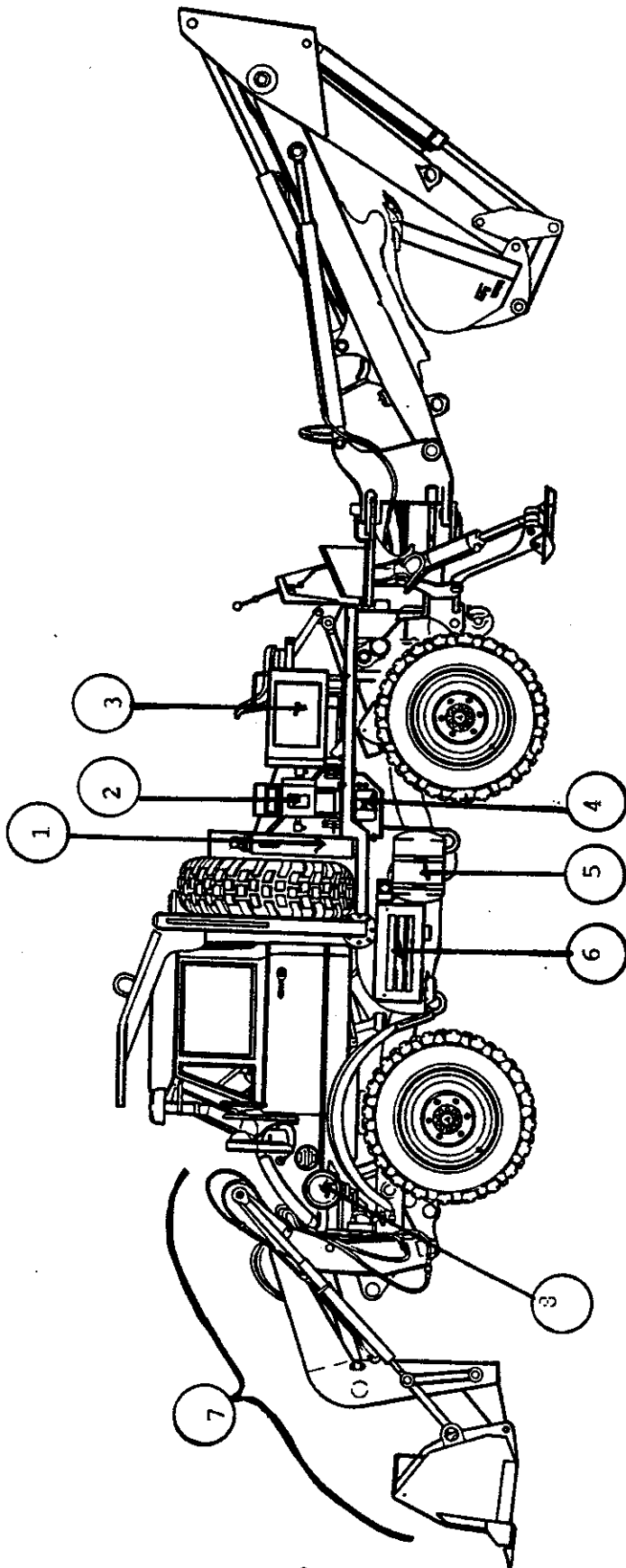

- | | |
|--|-------------------------|
| 1. FRONT HYDRAULIC SYSTEM RESERVOIR | 5. AIR SYSTEM RESERVOIR |
| 2. HYDRAULIC HAND TOOL HOSE REEL | 6. BATTERY BOX |
| 3. DUAL HYDRAULIC OIL COOLER | 7. FRONT LOADER |
| 4. BACKHOE TILT AND LOCK CONTROLS, TOOL AND WORK LIGHT SWITCHES | 8. AIR CLEANER |

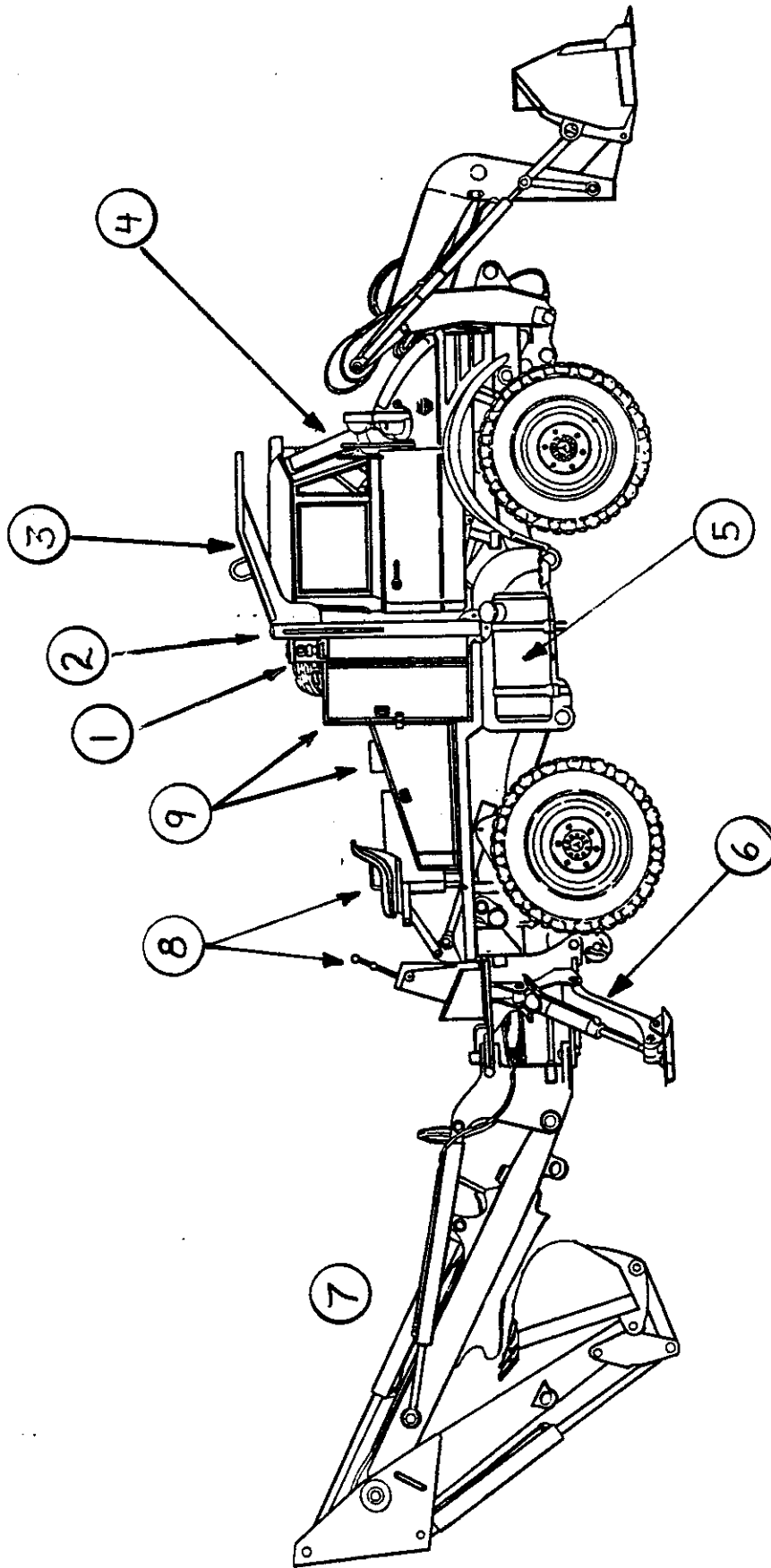

- | | |
|--|---|
| 1. REAR HYDRAULIC SYSTEM RESERVOIR | 6. BACKHOE STABILIZER |
| 2. ROLL OVER PROTECTION SYSTEM (ROPS) | 7. BACKHOE ASSEMBLY |
| 3. FALLING OBJECT PROTECTION SYSTEM (FOPS) | 8. BACKHOE OPERATOR SEAT AND CONTROLS |
| 4. TWO PERSONNEL STEEL CABS | 9. HYDRAULIC HAND TOOL STORAGE COMPARTMENTS |
| 5. FUEL TANK | |

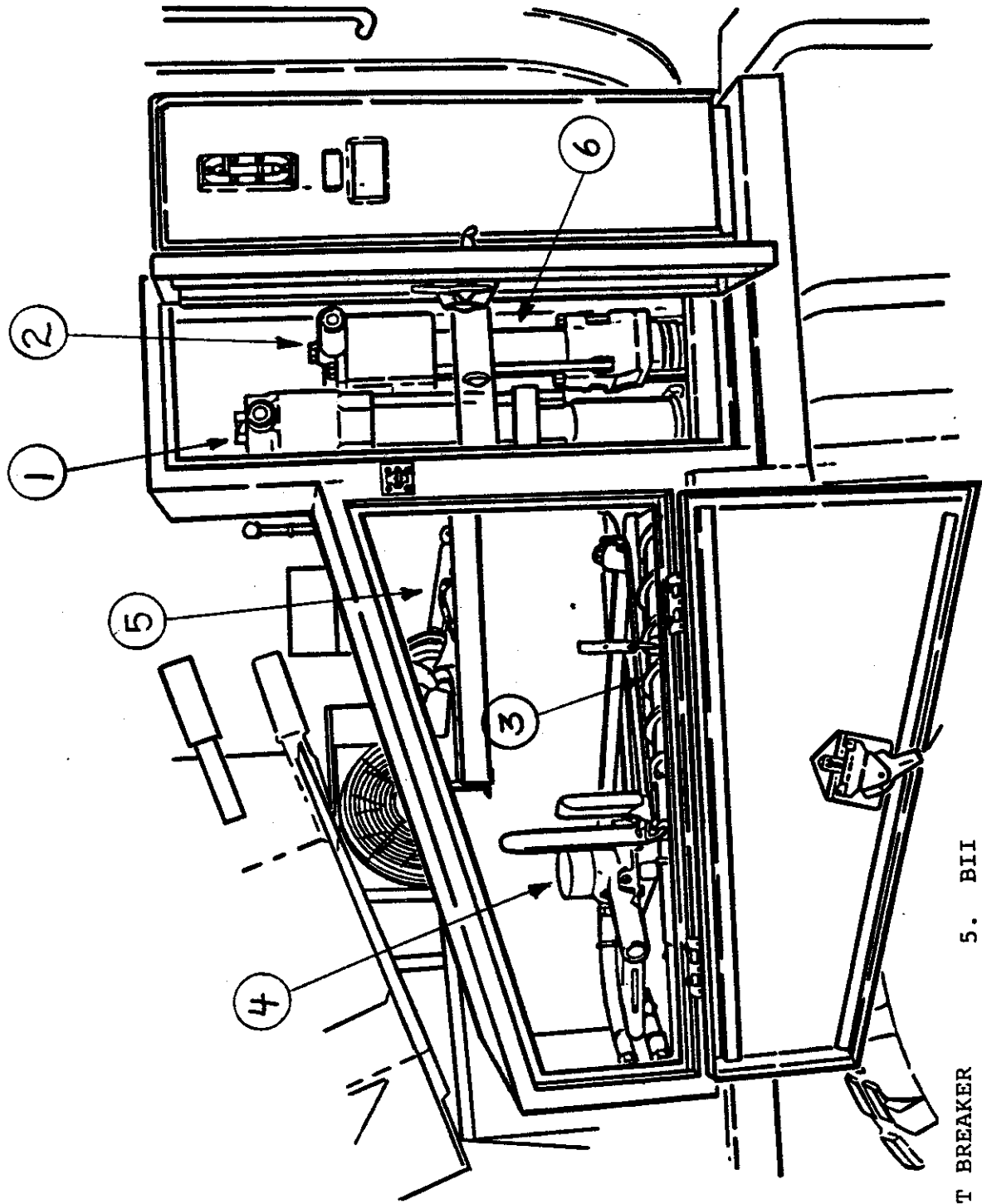

- 1. PAVEMENT BREAKER
- 2. HAMMER DRILL
- 3. BREAKER AND DRILL BITS
- 4. CHAIN SAW
- 5. BIT
- 6. REMOVABLE RIPPER

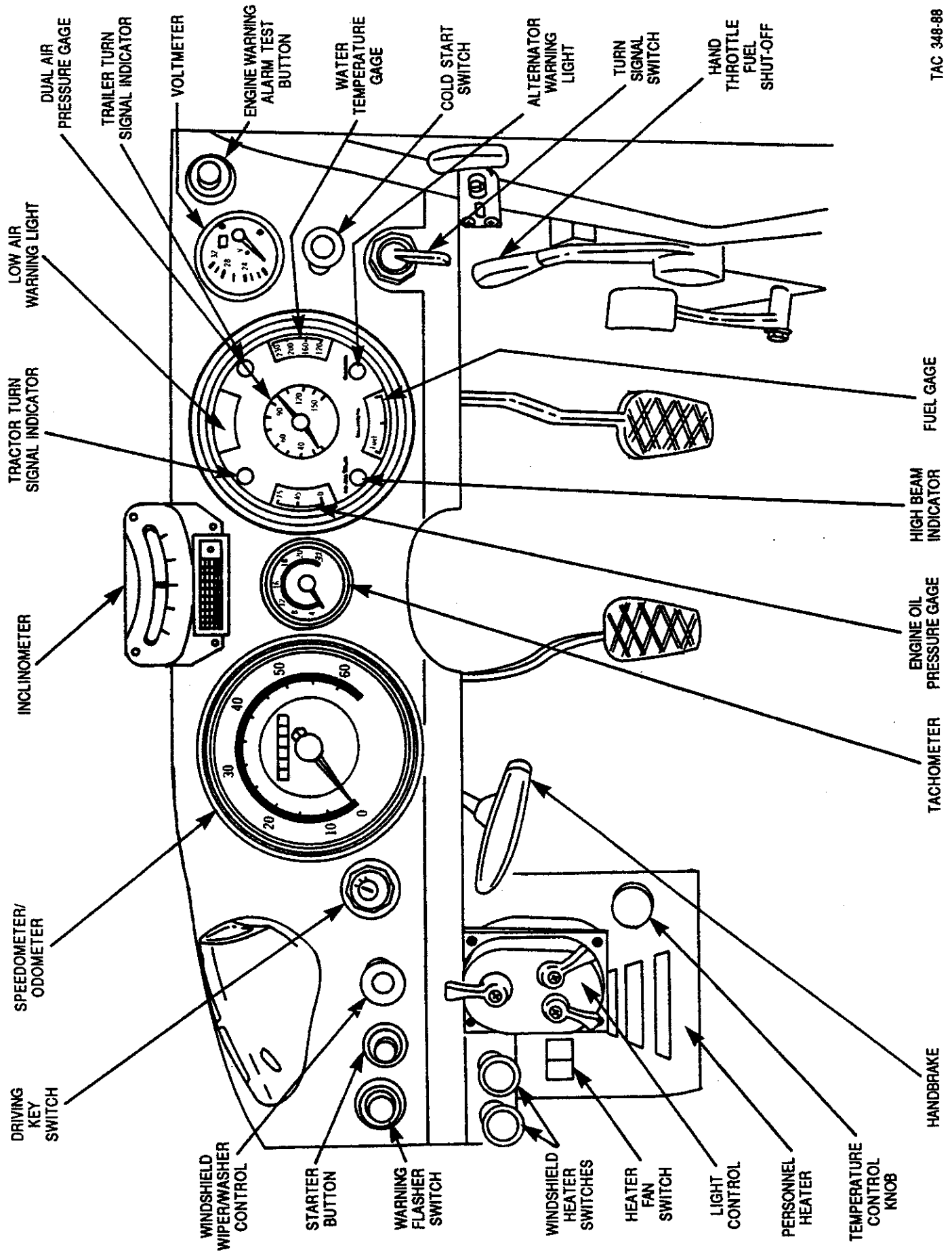

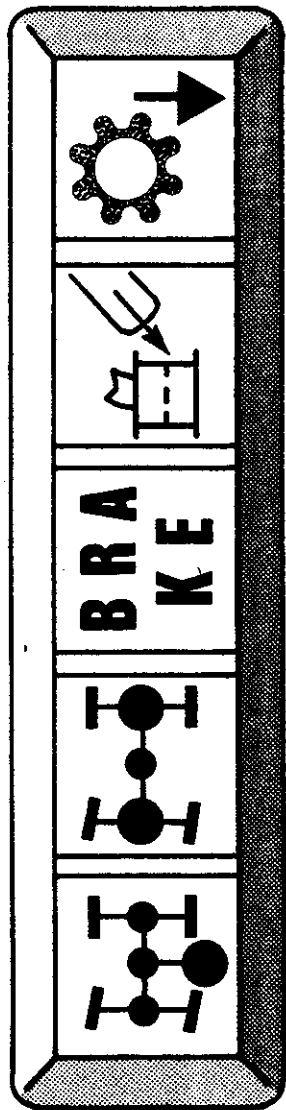
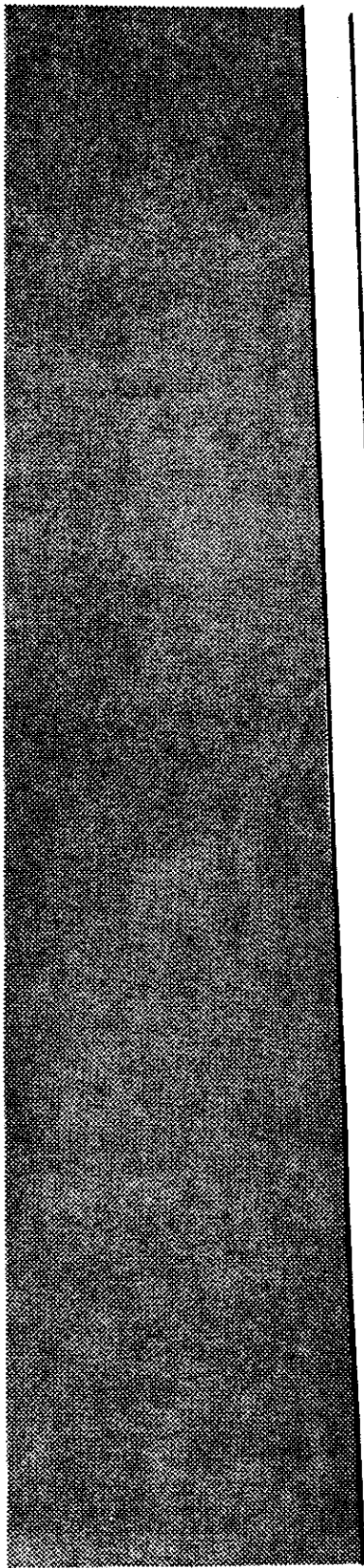

PTO

DIFF LOCK

BRAKE

AIR RES-
TRACTION

INTERMEDIATE
LOW SPEED
ENGAGED

HAND BRAKE
APPLIED,
FRONT PADS
WORN, OR
RESERVOIRS
LOW

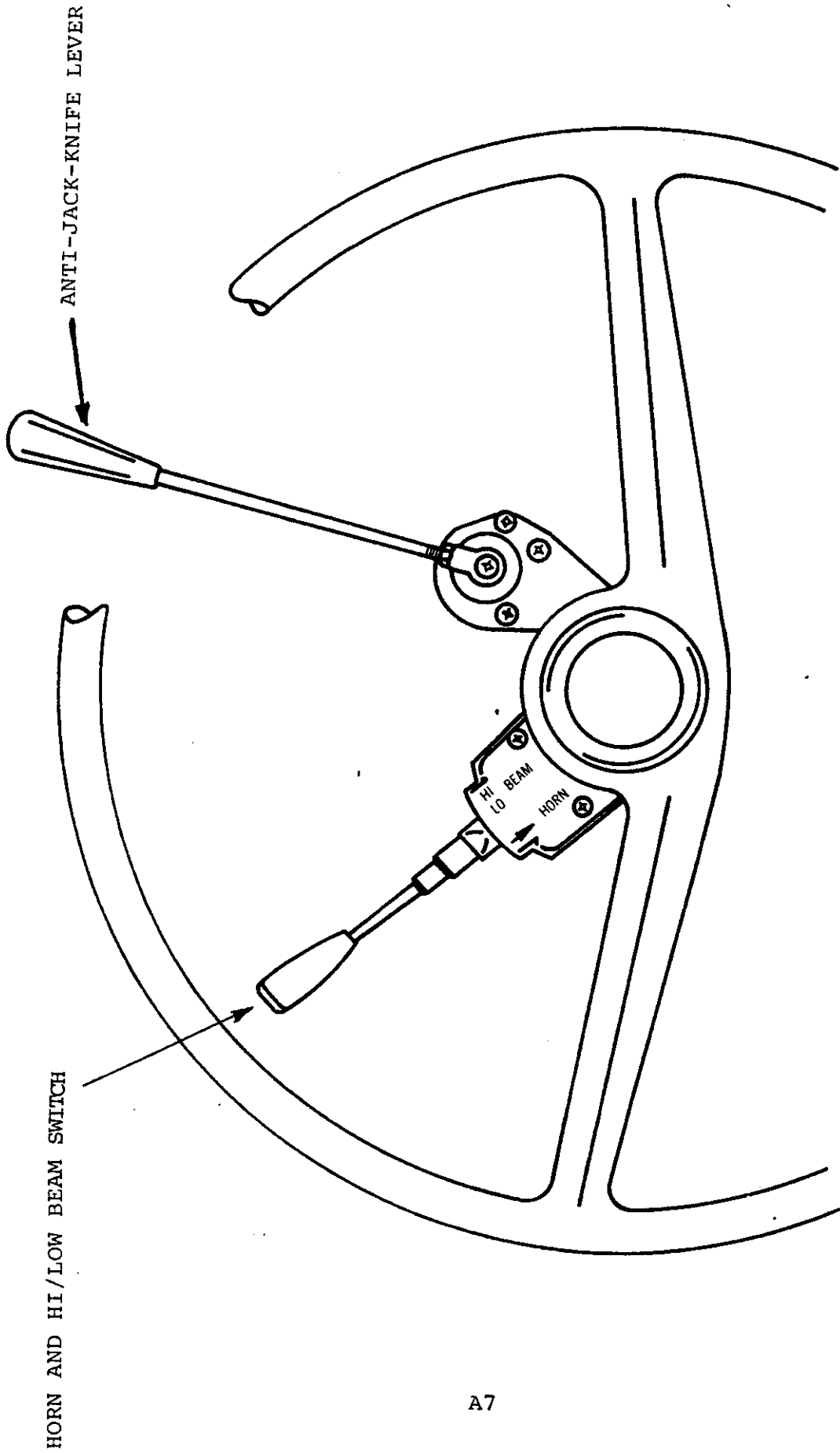

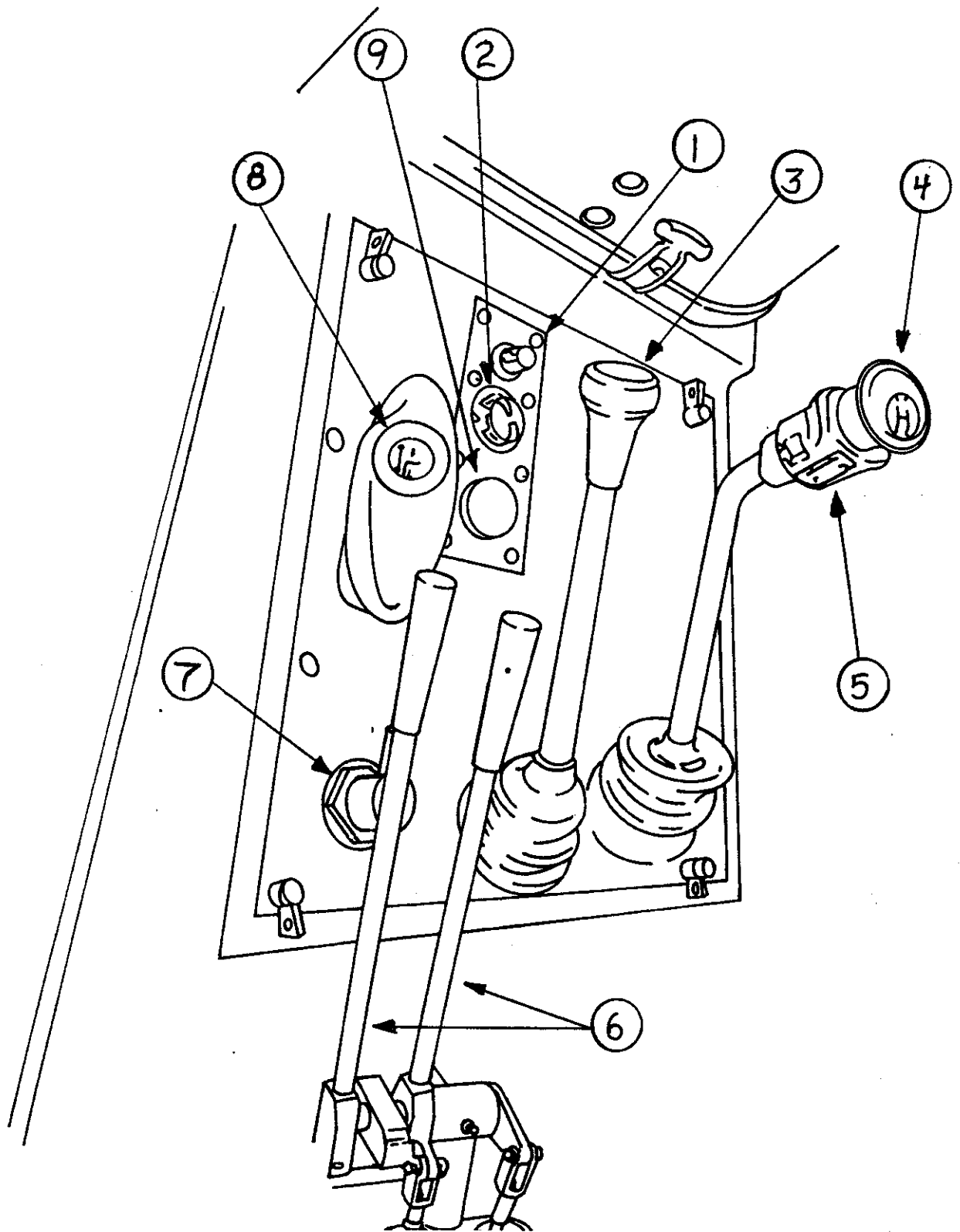

- | | |
|----------------------------------|--|
| 1. BATTERY DISCONNECT SWITCH | 6. FRONT LOADER CONTROL LEVERS |
| 2. TRAILER BRAKE CHARGING VALVE | 7. FOUR-WHEEL DRIVE/DIFFERENTIAL LOCK SWITCH |
| 3. RANGE/DIRECTION SHIFT LEVER | 8. POWER TAKE OFF SHIFT LEVER |
| 4. MAIN TRANSMISSION SHIFT LEVER | 9. DIAGNOSTIC CONNECTOR ASSEMBLY STE/IC |
| 5. INTERMEDIATE SPEED CONTROL | |

SMALL EMPLACEMENT EXCAVATOR (SEE)
STUDENT HANDOUT - MAINTENANCE
SCHEMATIC SET

TABLE OF CONTENTS

| <u>PAGE</u> | <u>DIAGRAM</u> | <u>DESCRIPTION</u> |
|-------------|---------------------|--|
| 1 | | WIRE INDEX |
| 2 | | WIRE INDEX (CON'T.) |
| | 1 (SHEET 1 OF 2) FO | ELECTRICAL DIAGRAM |
| | 1 (SHEET 2 OF 2) | ELECTRICAL DIAGRAM, IMPLEMENT WIRING |
| | 2 (FOLDOUT) | STARTING CIRCUIT DIAGRAM |
| | 3 (FOLDOUT) | CHARGING CIRCUIT DIAGRAM |
| | 4 (SHEET 1 OF 2) | STE/ICE WIRING DIAGRAM |
| | 4 (SHEET 2 OF 2) | STE/ICE WIRING DIAGRAM (CON'T.) |
| 3 | | FUSE PANEL INDEX |
| 4 | | ELECTRICAL RELAY POSITION |
| 5 | | HYDRAULIC BRAKE DIAGRAM |
| 6 | | AIR SYSTEM DIAGRAM |
| 7 | | AIR SYSTEM DIAGRAM, INITIAL CHARGE |
| 8 | | AIR SYSTEM DIAGRAM, STAGE I BRAKE BOOST |
| 9 | | AIR SYSTEM DIAGRAM, STAGE II BRAKE BOOST |
| 10 | | AIR SYSTEM DIAGRAM, ACCESSORIES |
| 11 | | AIR SYSTEM DIAGRAM, TRAILER BRAKE |
| 12 | | AIR SYSTEM DIAGRAM, TRAILER BRAKE |
| 13 | | AIR SYSTEM DIAGRAM, WHEN BEING TOWED |

SMALL EMPLACEMENT EXCAVATOR (SEE)
STUDENT HANDOUT - MAINTENANCE
SCHEMATIC SET

TABLE OF CONTENTS (CONTINUED)

| <u>PAGE</u> | <u>DIAGRAM</u> | <u>DESCRIPTION</u> |
|-------------|----------------------|---|
| 5 | | STANDARD GRAPHIC HYDRAULIC SYMBOLS |
| 6 | | STANDARD GRAPHIC HYDRAULIC SYMBOLS (CON'T.) |
| 7 | | STANDARD GRAPHIC HYDRAULIC SYMBOLS (CON'T.) |
| | 14 (SHEET 1 OF 2) FO | HYDRAULIC SCHEMATIC, FRONT SYSTEM |
| | 14 (SHEET 2 OF 2) FO | HYDRAULIC SCHEMATIC, FL-4 FRONT LOADER |
| | 15 (FOLD OUT) | HYDRAULIC SCHEMATIC, FRONT SYSTEM |
| | 16 (SHEET 1 OF 2) FO | HYDRAULIC SCHEMATIC, BACKHOE TILT & LOCK |
| | 16 (SHEET 2 OF 2) FO | HYDRAULIC SCHEMATIC, BACKHOE & STABILIZERS |
| 8 | | BACKHOE CIRCUIT RELIEF PRESSURES |

SMALL EMPLACEMENT EXCAVATOR (SEE)

WIRE INDEX

THE WIRE INDEX IS TO IDENTIFY INDIVIDUAL ELECTRICAL CIRCUITS ACCORDING TO THE WIRE NUMBERS.

NOTE

SOME WIRE NUMBERS BELOW ARE FOLLOWED BY A (-). THIS REPRESENTS ANY NUMBERS THAT FOLLOW. FOR EXAMPLE: 64- HORN. THIS MEANS ANY NUMBERS THAT START WITH 64, i.e., 641, 642, 643, etc., PERTAIN TO THE HORN CIRCUIT.

- 0- GROUNDS
- 1 REVERSE POLARITY SWITCH TO STARTER SOLENOID
- 11 STARTER SOLENOID TO DRIVING KEY SWITCH
- 111 STARTER SOLENOID TO B.O. LIGHT SWITCH
- 12 DRIVING KEY SWITCH TO FUSE BOX
- 121 DRIVING KEY SWITCH TO VOLTMETER
- 131 DRIVING KEY SWITCH TO FUSE BOX
- 132 DRIVING KEY SWITCH TO STARTER RELAY
- 141 ALTERNATOR TO REVERSE POLARITY SWITCH
- 21 DRIVING KEY SWITCH TO REVERSE POLARITY SWITCH
- 21- STARTING SYSTEM
- 22- INDICATOR LIGHTS (PTO, DIFF LOCK, BRAKE RESERVOIRS, INTERMEDIATE SPEED)
- 23- INTERMEDIATE SPEED SHIFT CIRCUIT
- 28- KBI (COLD START)
- 30 FUEL SENDING UNIT
- 30- ENGINE WARNING ALARM CIRCUIT
- 31- SENDING UNITS, OIL PRESS/WATER TEMP.
- 31S TACHOMETER SENSOR
- 33- LOW AIR PRESSURE ALARM/LIGHT
- 34 GROUND FOR CHARGING WARNING LIGHT/TACHOMETER
- 34- ALTERNATOR TO NON-REPEAT RELAY AND ENGINE WARNING ALARM SYSTEM

SMALL EMPLACEMENT EXCAVATOR (SEE)

WIRE INDEX (CON'T.)

- 35- BACK-UP ALARM
- 36- TACHOMETER/CHARGING WARNING LIGHT
- 37 DRIVING KEY SWITCH TO COMBINATION GAUGE
- 371 AIR FILTER RESTRICTION INDICATOR
- 372 FUSE BOX TO INDICATOR LAMPS
- 39- TURN SIGNAL INDICATOR LAMPS

ALL WIRE NUMBERS THAT BEGIN WITH 4 ARE FOR LIGHTS

- 40- B.O. HEADLIGHT
- 41- HEADLIGHTS/PARKLIGHTS
- 42- UPPER HEADLIGHTS/REAR WORK LIGHTS
- 43- CAB INTERIOR LIGHT
- 44- REAR TURN SIGNAL LIGHTS/BRAKE LIGHTS
- 45- FRONT TURN SIGNAL LIGHTS
- 46- WARNING LIGHT SENDING UNIT TO WARNING LIGHT SWITCH
- 47- B.O. BRAKE LIGHTS
- 48- B.O. MARKER LIGHTS
- 49- DASH PANEL LIGHTS

ALL WIRE NUMBERS THAT BEGIN WITH 6 ARE FOR CAB ACCESSORIES

- 61- HEATER FAN
- 62- WINDSHIELD HEATER CIRCUIT
- 63- WIPER/WASHER CIRCUIT
- 64- HORN
- 66- UTILITY OUTLET
- 70- IMPLEMENT WIRING

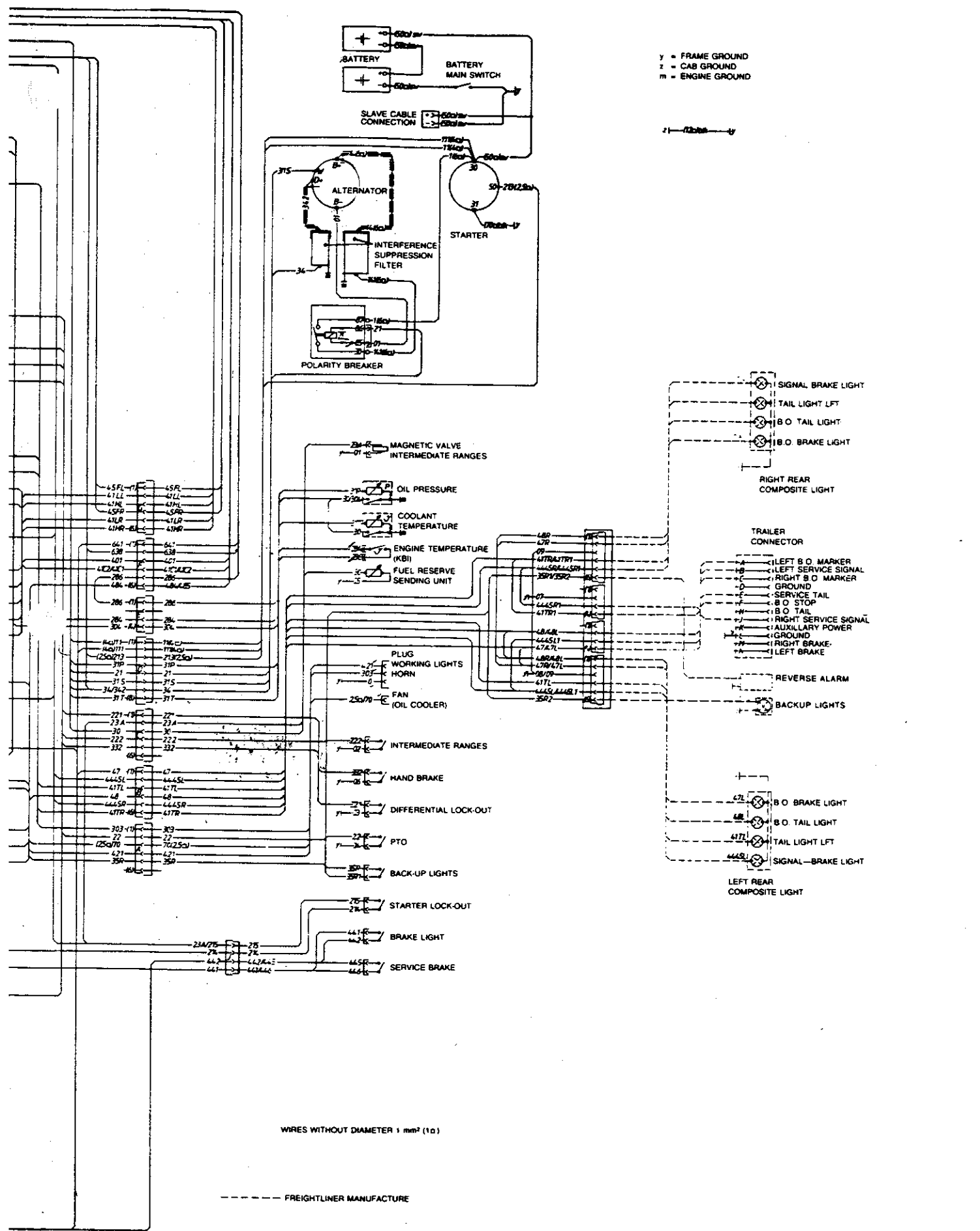
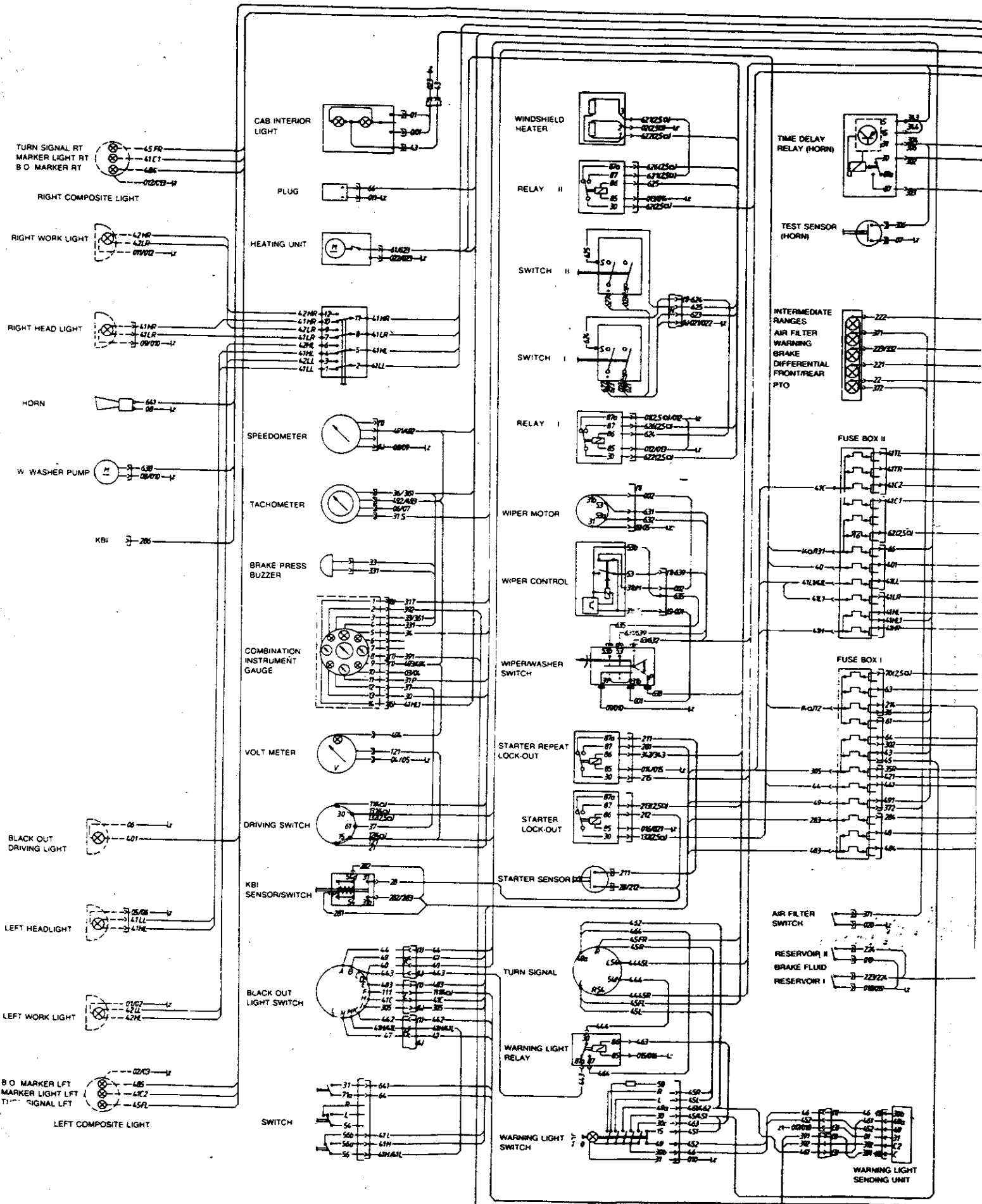

DIAGRAM 1 SEE ELECTRICAL (SHEET 1 OF 2)



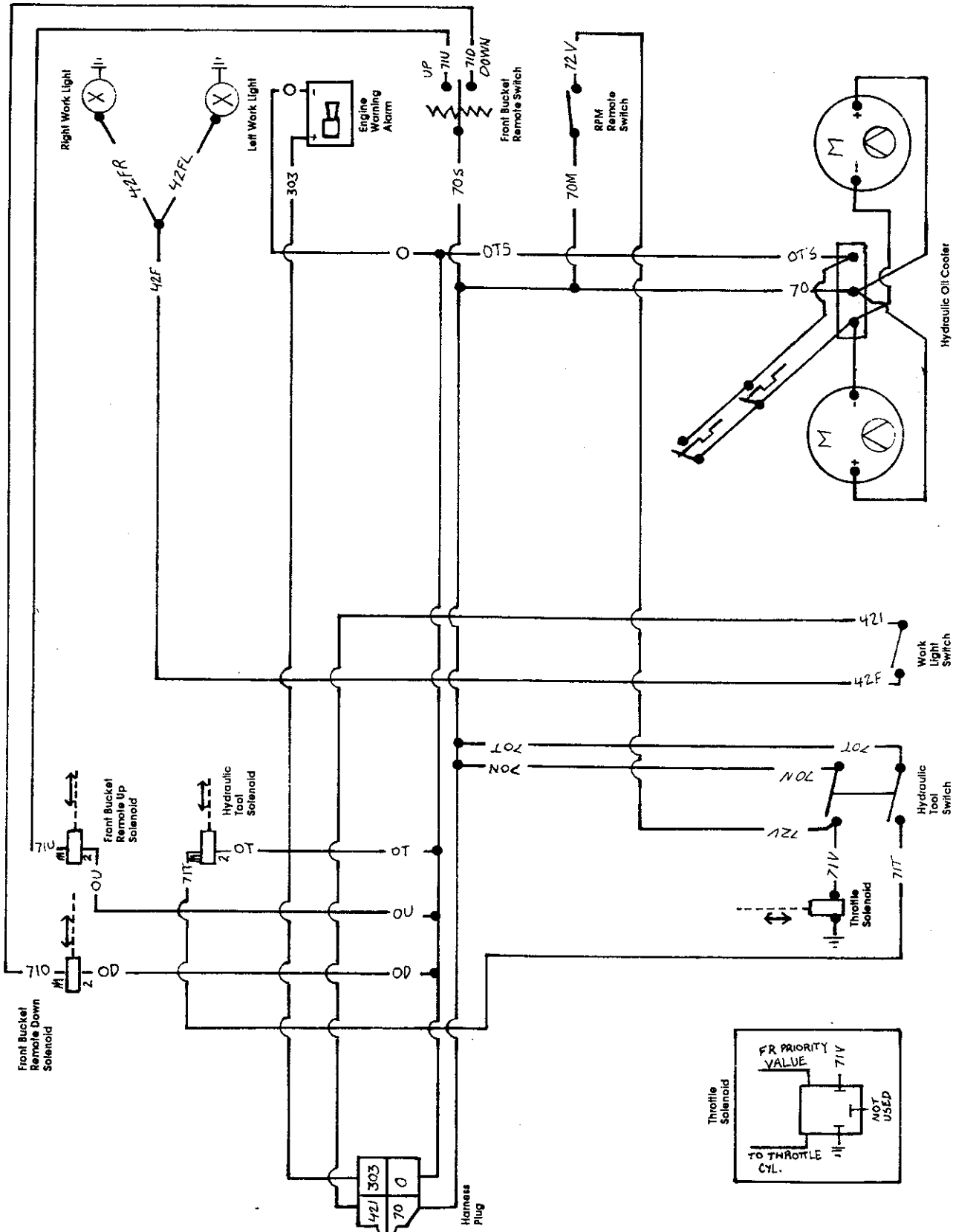
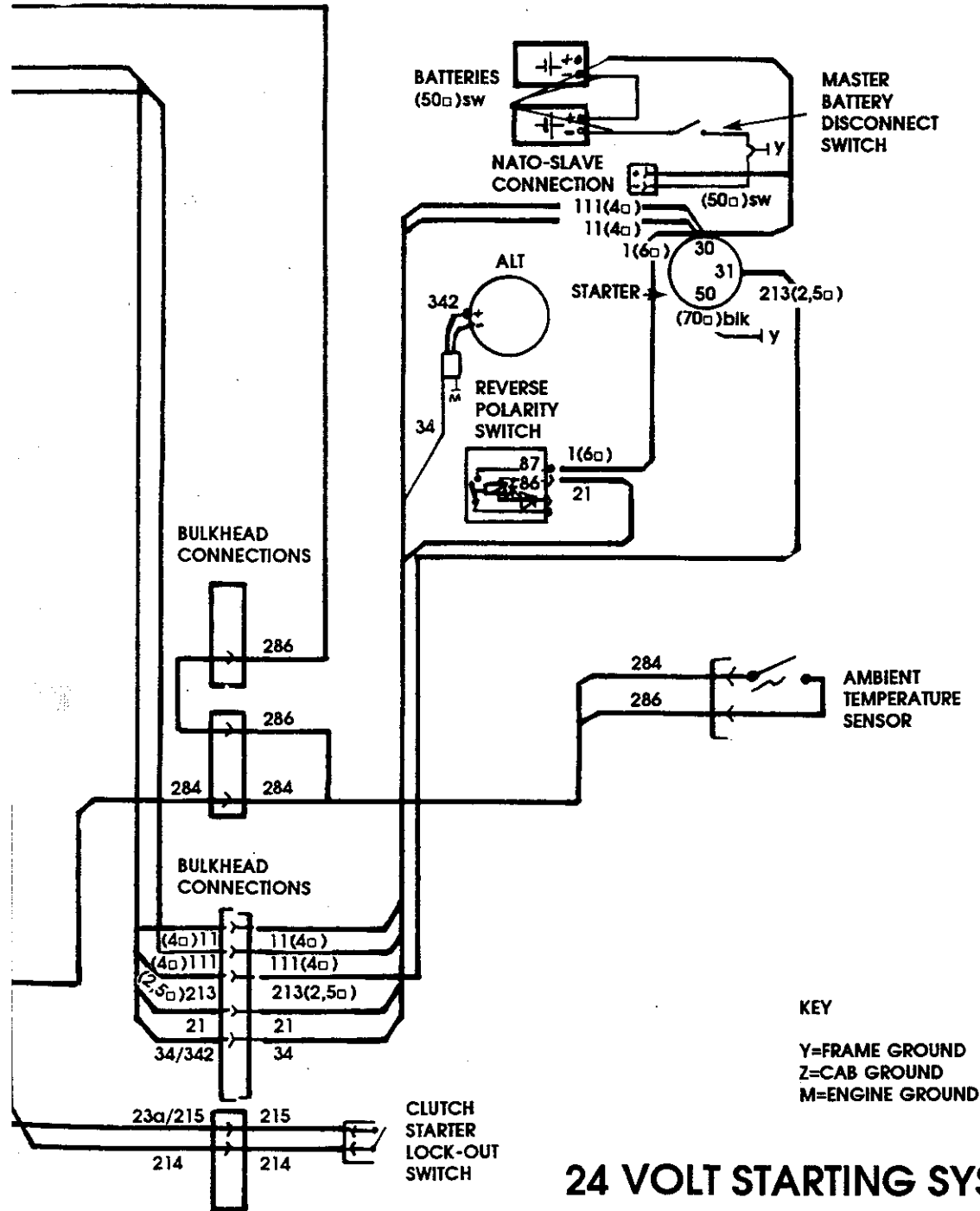

DIAGRAM 1

SEE ELECTRICAL



**24 VOLT STARTING SYSTEM
S.E.E.
TRACTOR WHEEL 4x4 DED**

ETHER INJECTOR 286

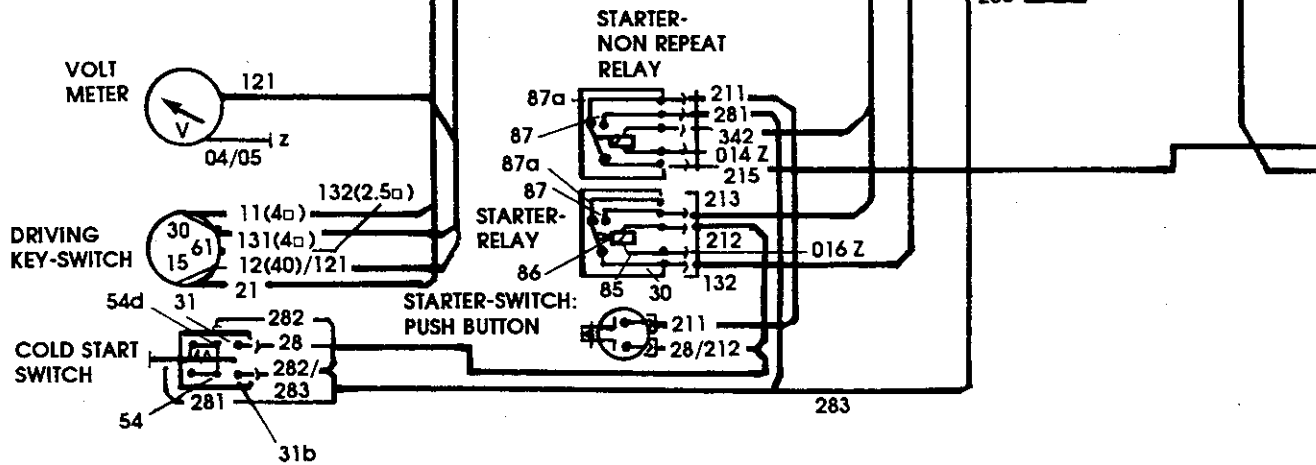

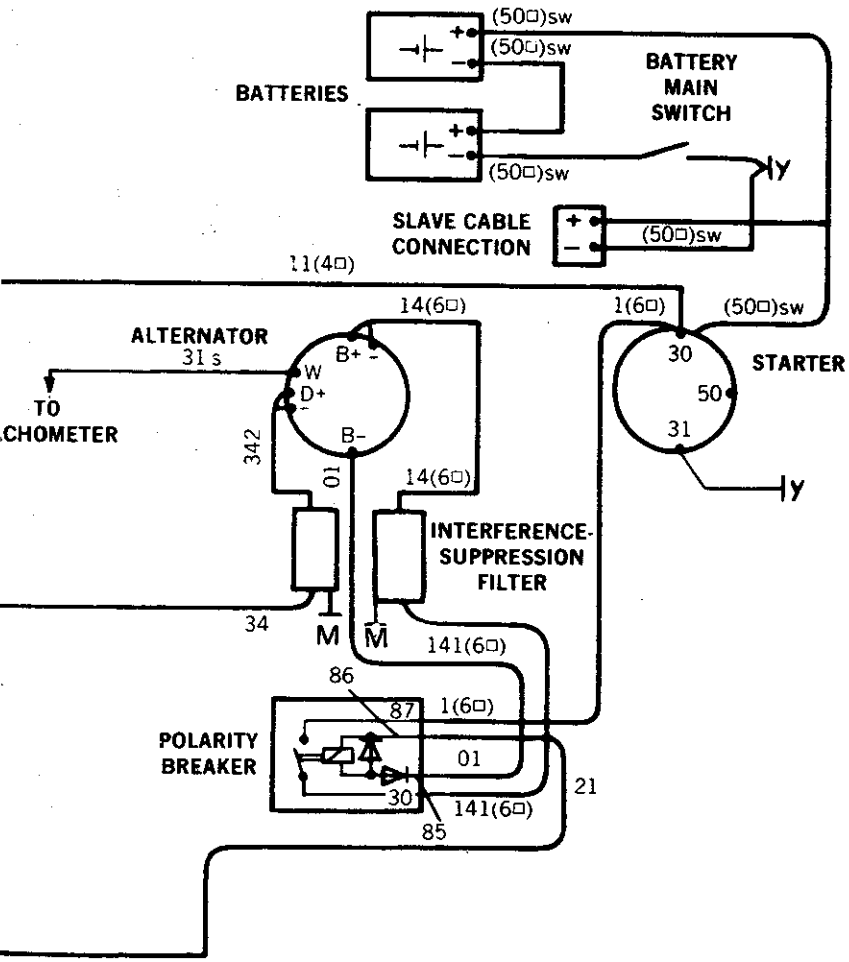

KEY
 Y FRAME GROUND
 Z CAB GROUND
 M ENGINE GROUND

24 VOLT CHARGING SYSTEM
 S.E.E.
 TRACTOR WHEEL 4x4 DED

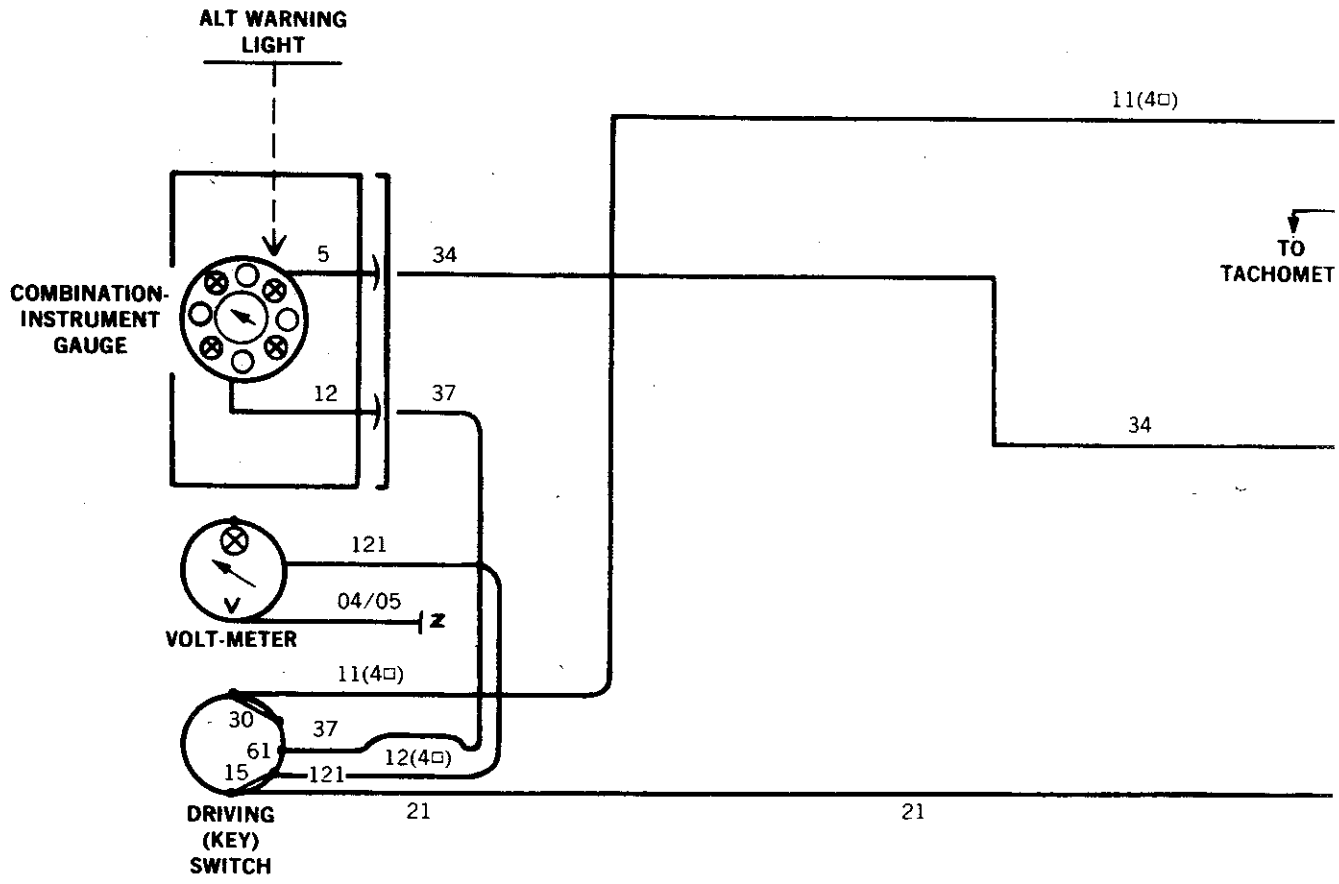

STE/ICE SYSTEM

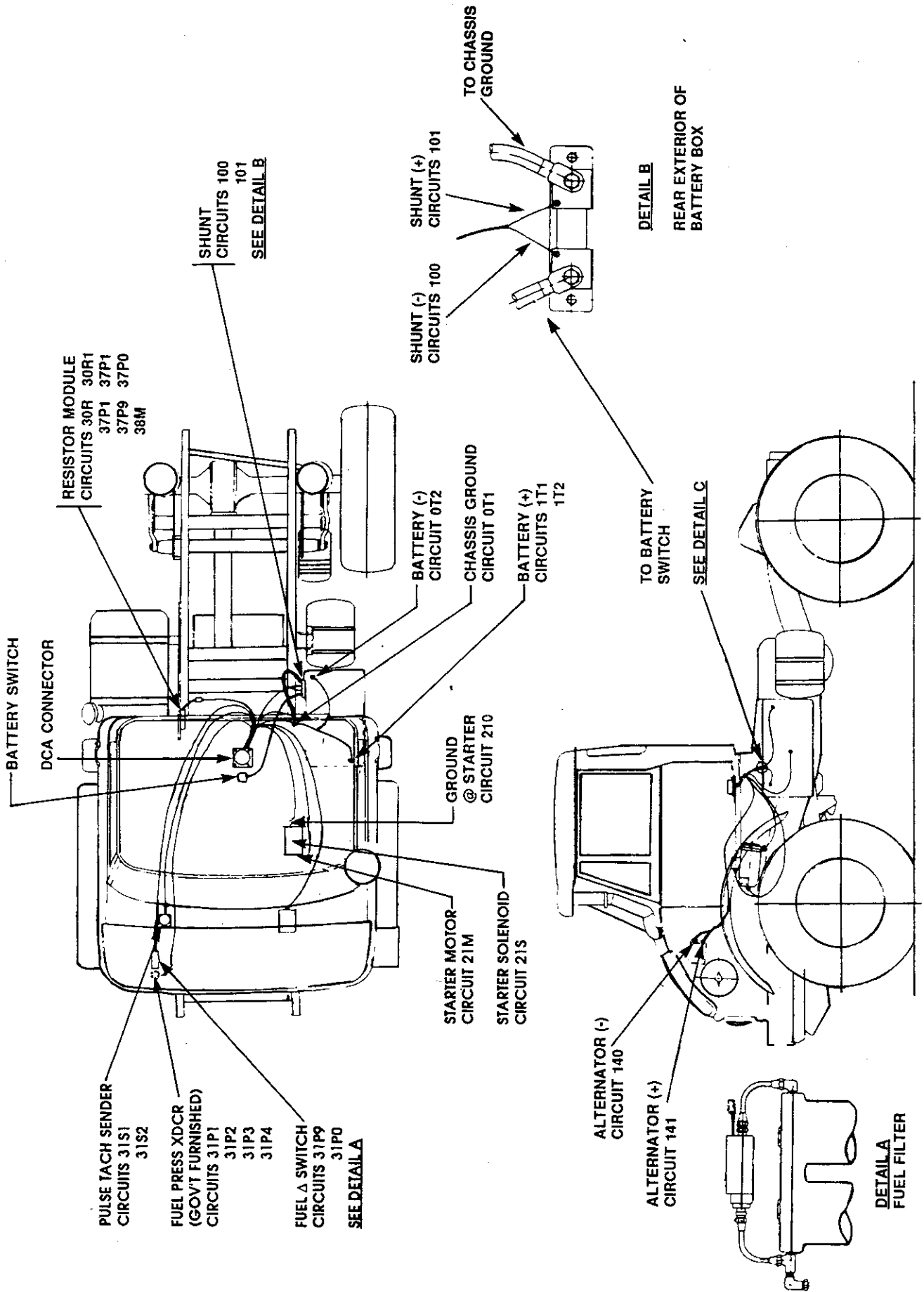
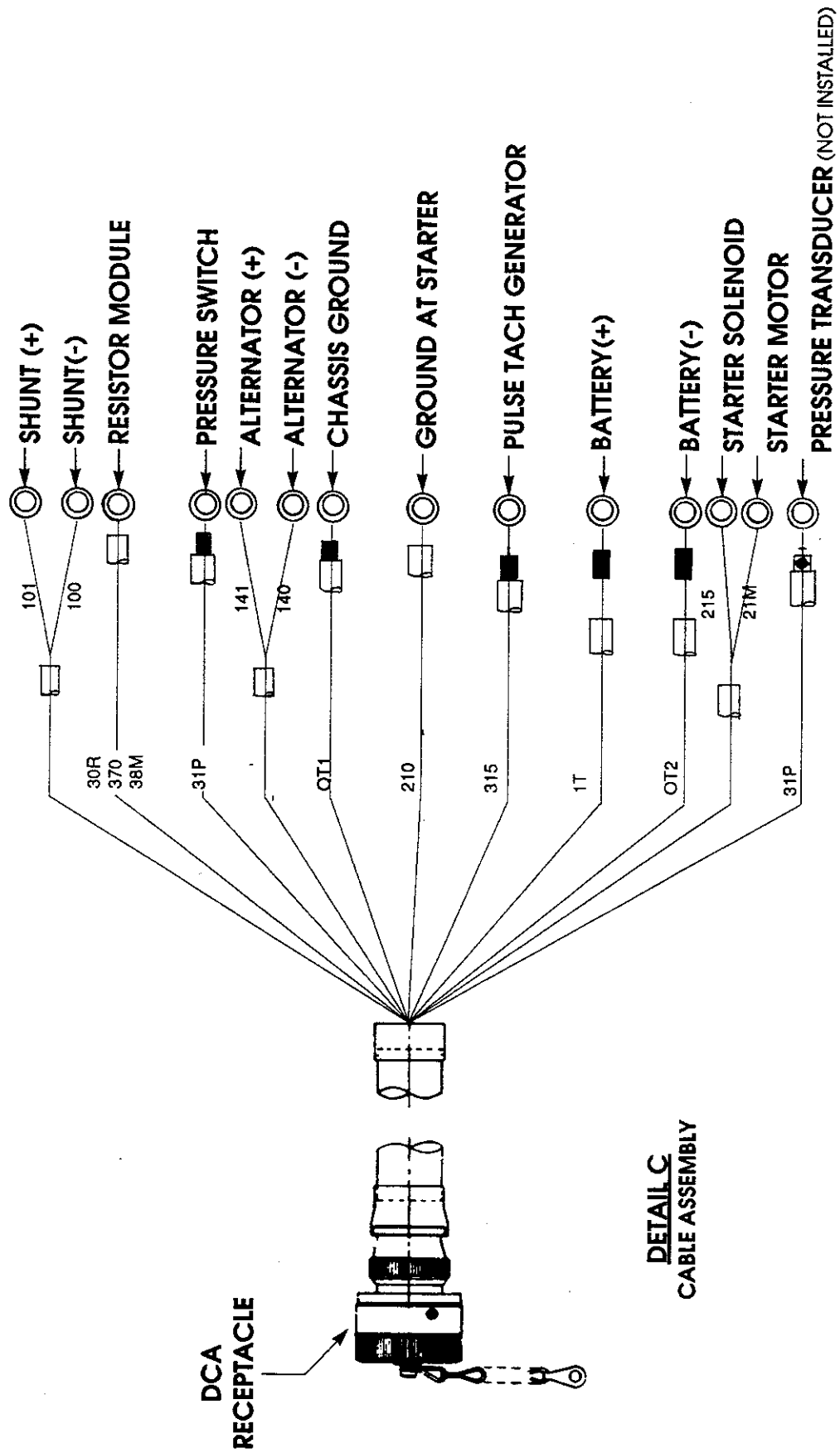

DIAGRAM 4

STE/ICE SYSTEM



DETAIL C
CABLE ASSEMBLY

DIAGRAM 4

FUSE PANEL INDEX

| FUSE INDEX | NO. | FUSE BOX II | A |
|------------|-----|---|----|
| F1 | 1 | TAIL LIGHT LEFT | 8 |
| F2 | 2 | TAIL LIGHT RIGHT | 8 |
| F3 | 3 | SIDE MARKER LIGHT LEFT | 8 |
| F4 | 4 | SIDE MARKER LEFT RIGHT | 8 |
| F5 | 5 | SPARE | 8 |
| F6 | 6 | HEATED WINDSHIELD | 16 |
| F7 | 7 | SOCKET | 8 |
| F8 | 8 | BLACKOUT HEAD LIGHT | 8 |
| F9 | 9 | LOW BEAM LEFT | 8 |
| F10 | 10 | LOW BEAM RIGHT | 8 |
| F11 | 11 | HIGH BEAM LEFT HIGH BEAM LEFT INDICATOR LAMP, HIGH BEAM | 8 |
| F12 | 12 | HIGH BEAM RIGHT | 8 |

| FUSE INDEX | NO. | FUSE BOX I | A |
|------------|-----|---|----|
| F13 | 1 | AIR THROTTLE CONTROL CIRCUIT, OIL COOLER FAN AND TEMPERATURE SWITCH, TOOL CIRCUIT SWITCH, FRONT LOADER REMOTE CIRCUIT | 16 |
| F14 | 2 | WINDSHIELD WIPER | 8 |
| F15 | 3 | INSTRUMENTS, SAFETY START | 8 |
| F16 | 4 | HEATING | 8 |
| F17 | 5 | HORN, WARNING BUZZER | 8 |
| F18 | 6 | TURN SIGNAL, HAZARD WARNING FLASHER, CAB LIGHT | 8 |
| F19 | 7 | WORKING LAMP, BACKUP CONTROL | 16 |
| F20 | 8 | STOP LIGHT | 8 |
| F21 | 9 | CONTROL LAMP, INSTRUMENT LAMP | 8 |
| F22 | 10 | KBI-COLD START SENSOR | 8 |
| F23 | 11 | BLACKOUT TAIL LIGHT | 8 |
| F24 | 12 | BLACKOUT HEAD LIGHT | 8 |

ELECTRICAL RELAY POSITION

NOTE:

1. ALL RELAYS ARE INTER-CHANGEABLE
2. BOTH NON-REPEAT AND STARTER RELAYS MUST BE SERVICABLE TO START VEHICLE
3. RELAY SOCKET IDENTIFICATION:

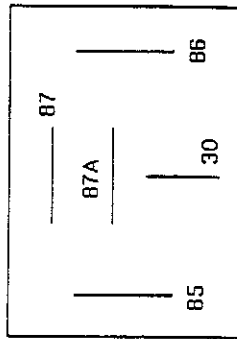

HEAD LIGHT SWITCH

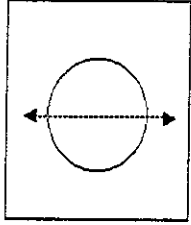

STARTER
NON
REPEAT

STARTER

WARNING
LIGHT
(EFFECTS WARNING
LIGHTS ON REAR OF
S.E.E. AND TRAILER)

WINDSHIELD
HEATER

WINDSHIELD
HEATER

SEE HYDRAULIC BRAKE DIAGRAM

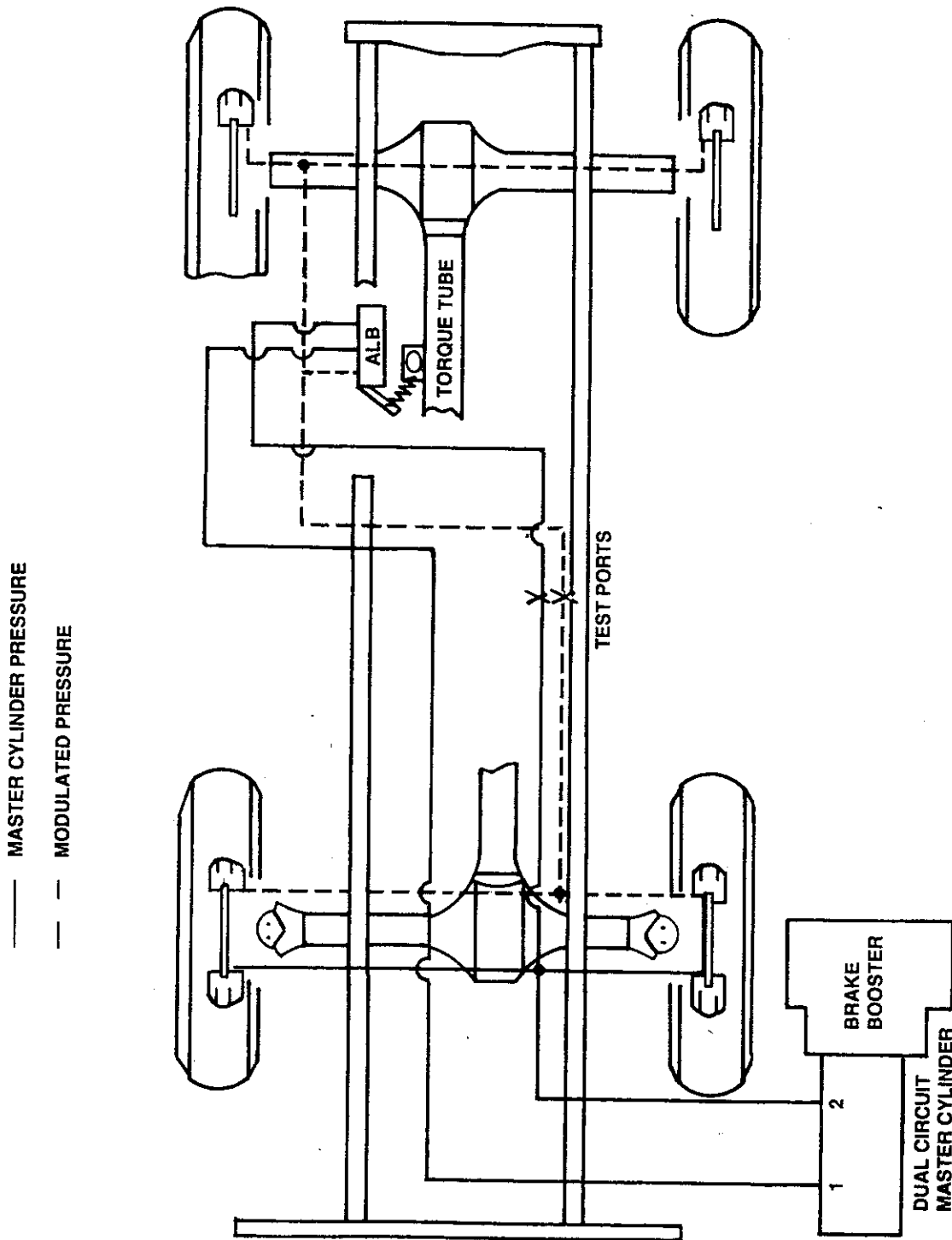

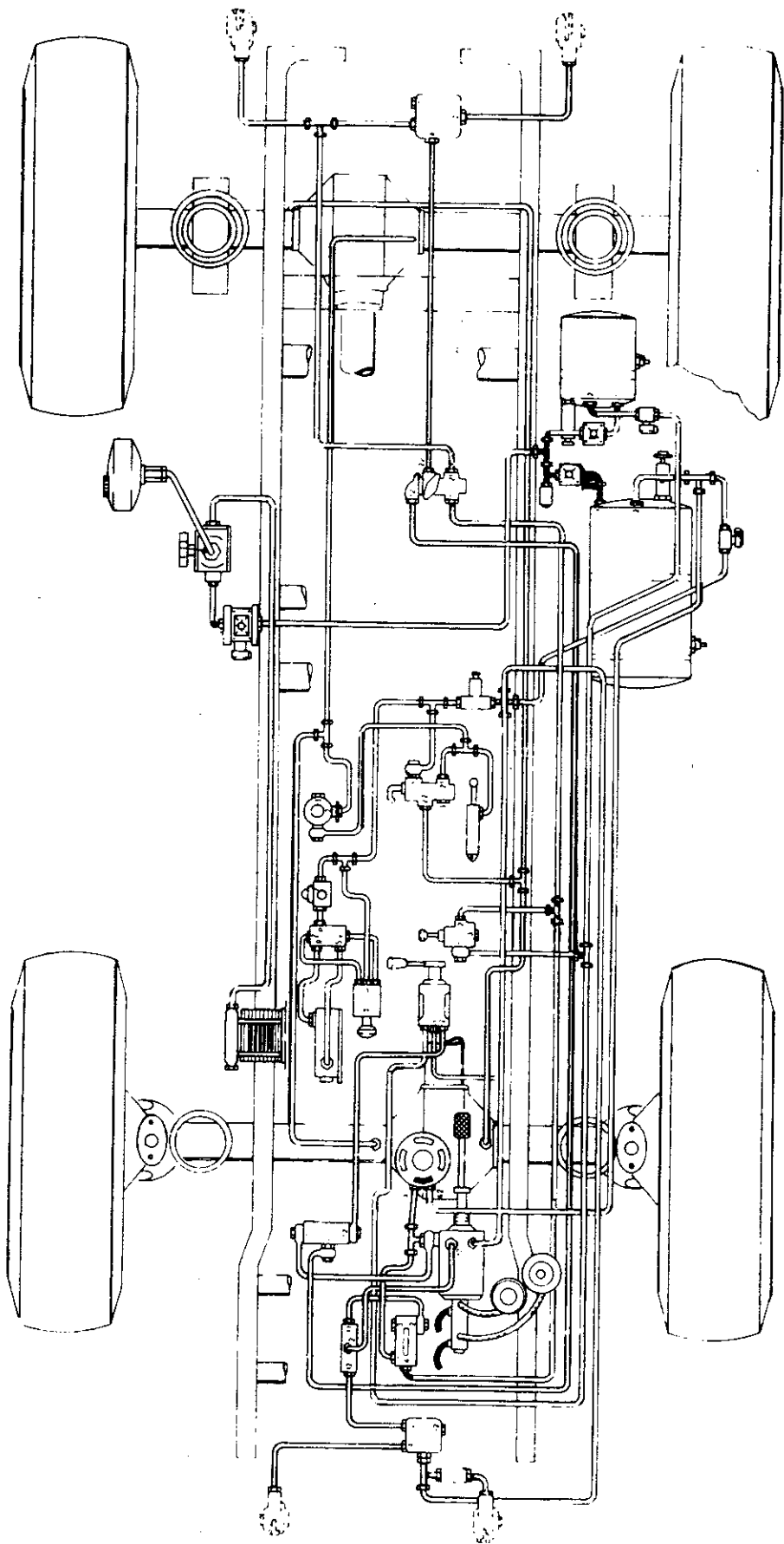
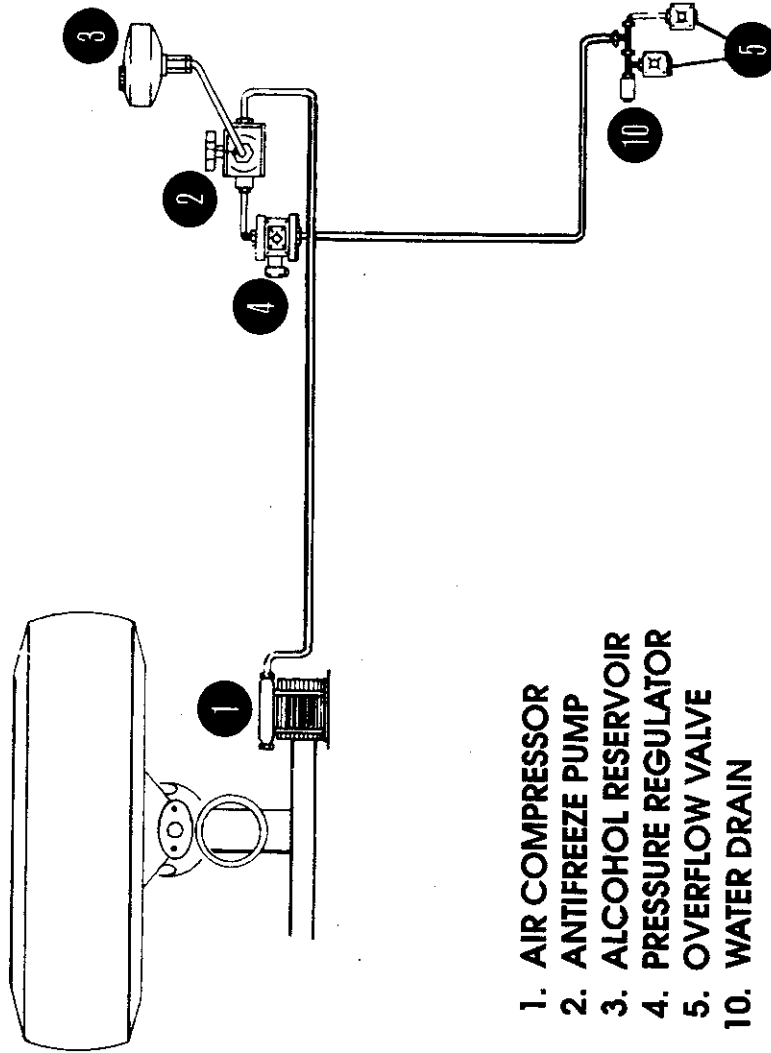

DIAGRAM 6

S.E.E. AIR SYSTEM INITIAL CHARGE CIRCUIT



- 1. AIR COMPRESSOR
- 2. ANTIFREEZE PUMP
- 3. ALCOHOL RESERVOIR
- 4. PRESSURE REGULATOR
- 5. OVERFLOW VALVE
- 10. WATER DRAIN

S.E.E. AIR SYSTEM PRIMARY SUPPLY/STAGE I BRAKE BOOST

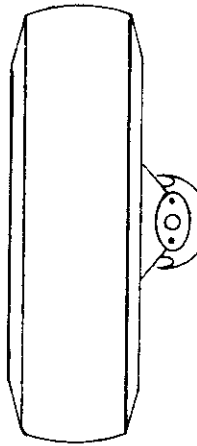

- 5. OVERFLOW VALVE
- 7. AIR RESERVOIR; LARGE
- 8. TEST CONNECTION
- 9. SAFETY VALVE
- 10. RESERVOIR DRAIN
- 11. BRAKE BOOSTER
- 12. MASTER CYLINDER
- 13. DUAL AIR PRESSURE GAUGE

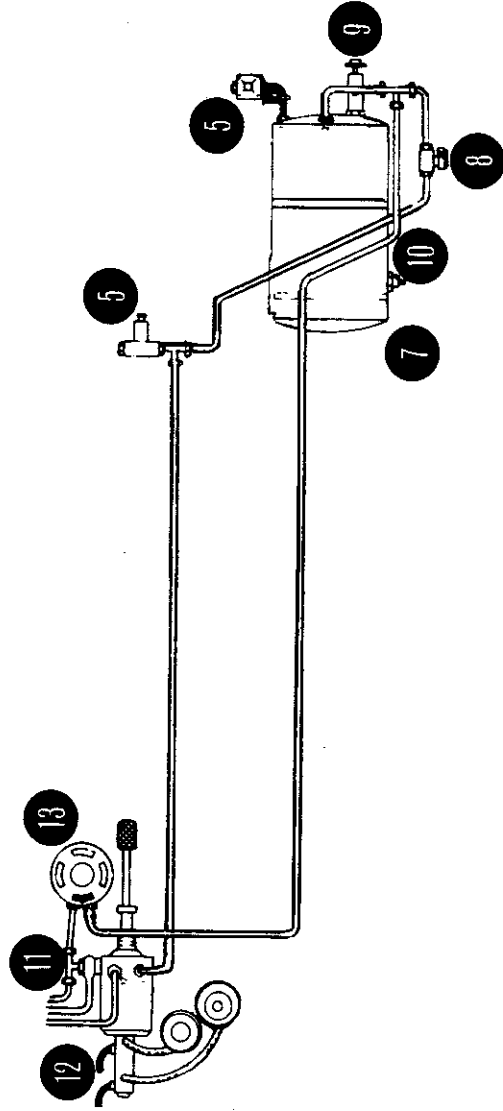
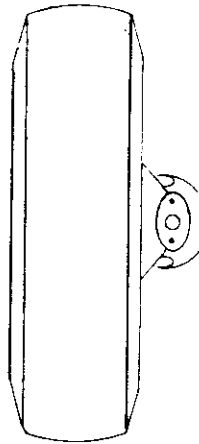
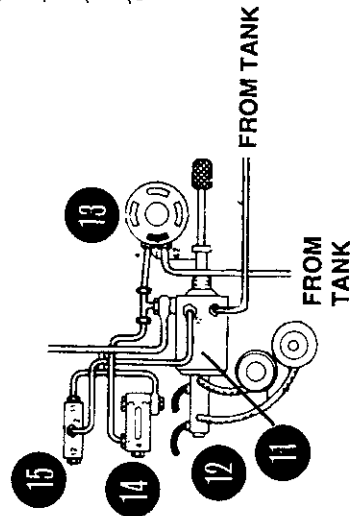

DIAGRAM 8

S.E.E. AIR SYSTEM SERVICE BRAKE APPLIED/STAGE II BRAKE BOOST



- 11. BRAKE BOOSTER
- 12. MASTER CYLINDER
- 13. DUAL AIR PRESSURE GAUGE
- 14. 3/2 WAY VALVE
- 15. SHUTTLE VALVE



S.E.E. AIR SYSTEM ACCESSORIES CIRCUITS (4WD, DIFF. LOCK, INTER. SPEED SHIFT, HIGH IDLE)

- | | |
|--|--|
| <ul style="list-style-type: none"> 5. OVERFLOW VALVE 7. AIR RESERVOIR, LARGE 8. TEST CONNECTION 10. RESERVOIR DRAIN 23. 4WD, DIFF LOCK CONTROL 24. 4WD SHIFT CYLINDER 25. PRESSURE REDUCING VALVE | <ul style="list-style-type: none"> 27. INTER. SPEED SHIFT COLLAR 28. SOLENOID SWITCH 29. INTER. SPEED CONTROL VALVE 30. INTER. SPEED SHIFT CYLINDER 31. SOLENOID SWITCH 32. HIGH IDLE CYLINDER |
|--|--|

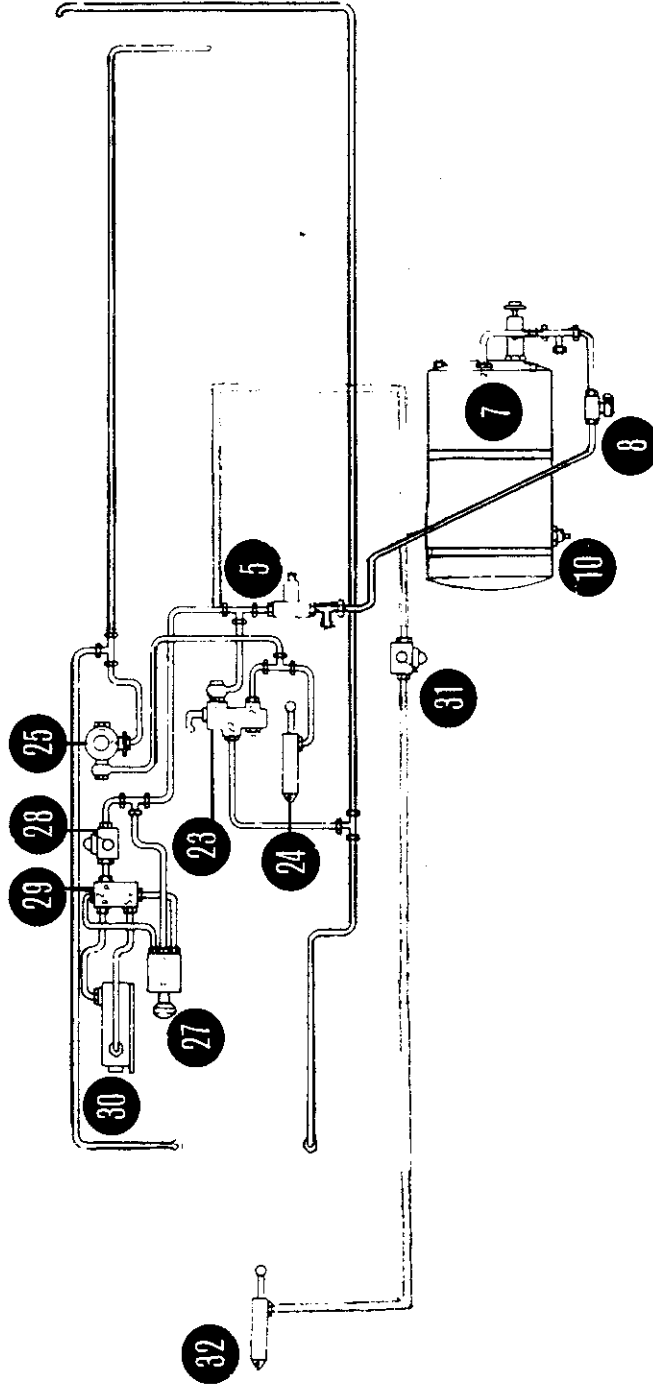
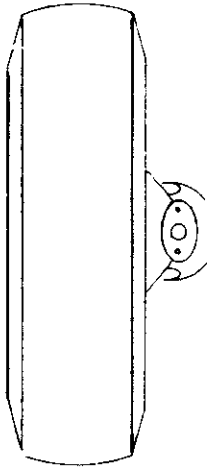

S.E.E. AIR SYSTEM

TRAILER BRAKE/STAGE II CUT-OUT CIRCUIT (BRAKE PEDAL APPLIED)

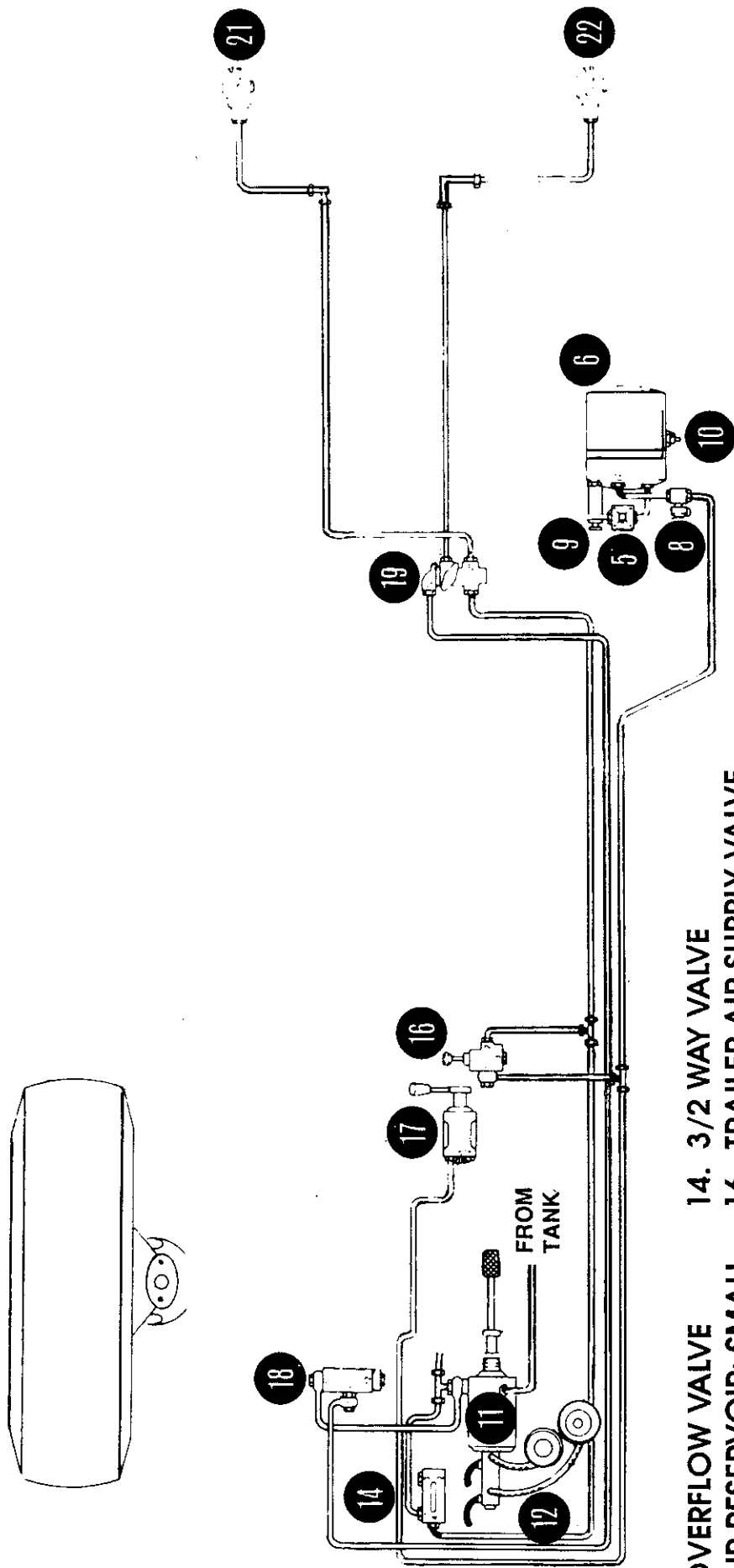

- 5. OVERFLOW VALVE
- 6. AIR RESERVOIR; SMALL
- 8. TEST CONNECTION
- 9. SAFETY VALVE
- 10. RESERVOIR DRAIN
- 11. BRAKE BOOSTER
- 12. MASTER CYLINDER
- 14. 3/2 WAY VALVE
- 16. TRAILER AIR SUPPLY VALVE
- 17. ANTI-JACKKNIFE HANDLE
- 18. SHUTTLE VALVE
- 19. TRACTOR PROTECTION VALVE
- 21. GLAD HAND, BLUE
- 22. GLAD HAND, RED

S.E.E. AIR SYSTEM TRAILER BRAKE/STAGE II CUT-OUT CIRCUIT (TRAILER BRAKE HANDLE APPLIED)

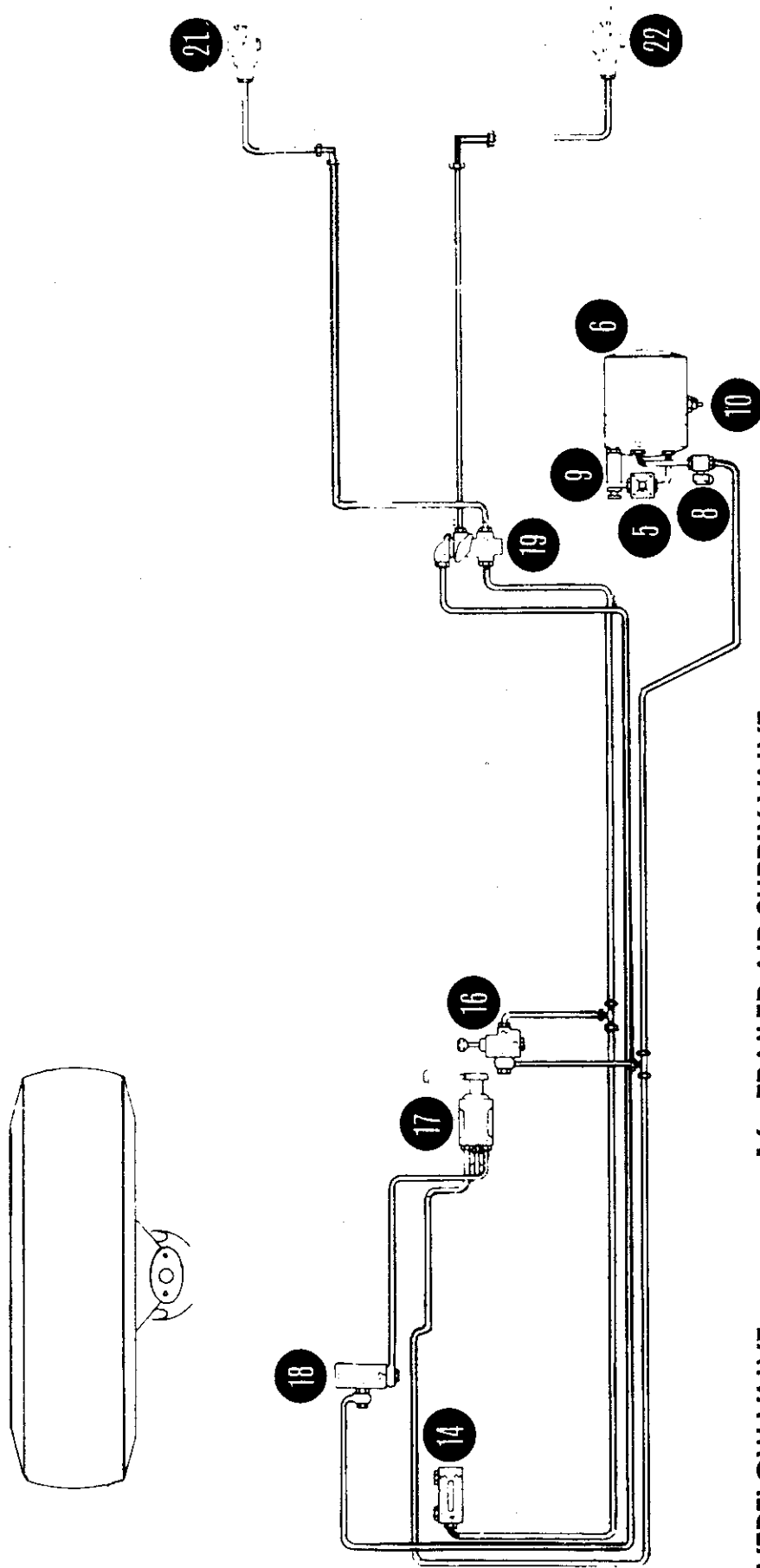

- | | |
|---|---|
| <ul style="list-style-type: none"> 5. OVERFLOW VALVE 6. AIR RESERVOIR, SMALL 8. TEST CONNECTION 9. SAFETY VALVE 10. RESERVOIR DRAIN 14. 3/2 WAY VALVE | <ul style="list-style-type: none"> 16. TRAILER AIR SUPPLY VALVE 17. ANTI-JACKKNIFE HANDLE 18. SHUTTLE VALVE 19. TRACTOR PROTECTION VALVE 21. GLAD HAND; BLUE 22. GLAD HAND; RED |
|---|---|



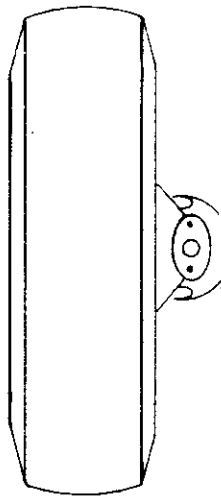



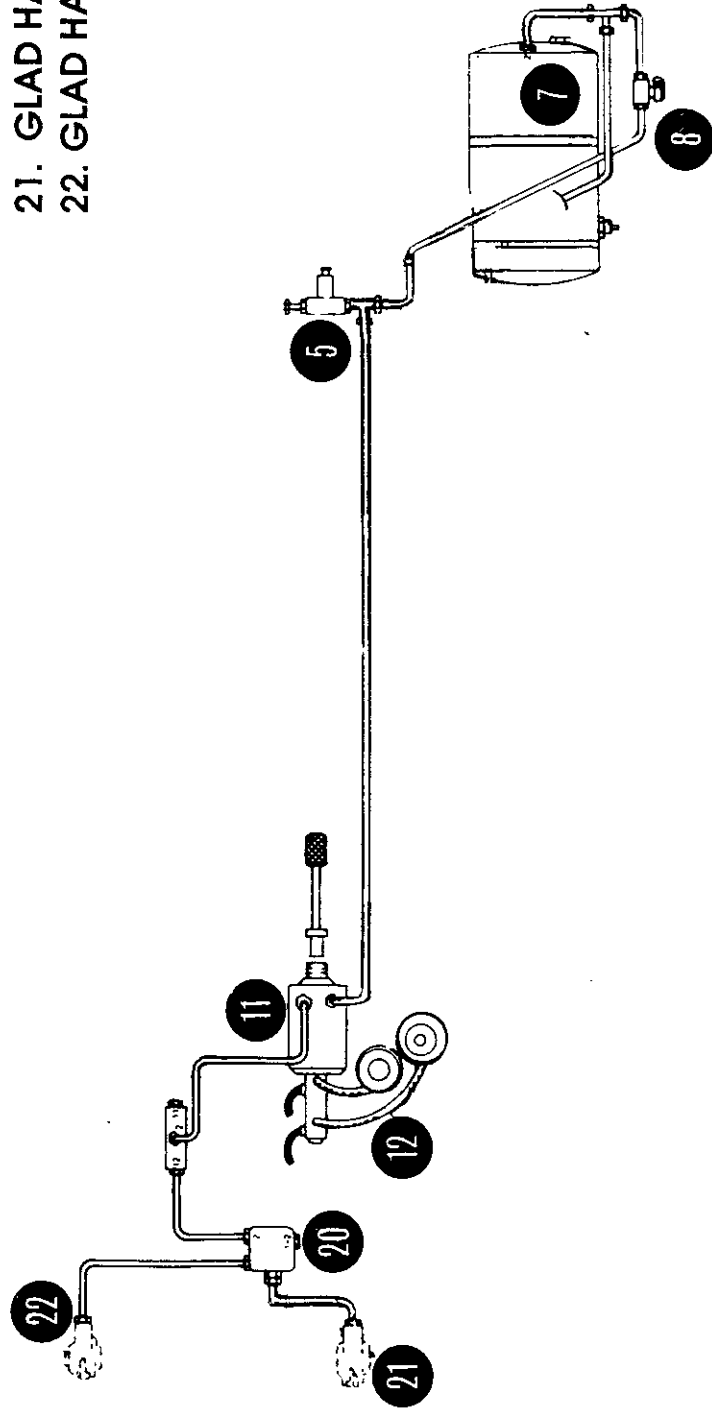



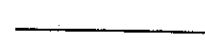

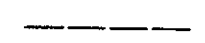

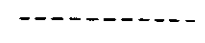

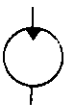
S.E.E. AIR SYSTEM BRAKE CIRCUIT (WHEN BEING TOWED)





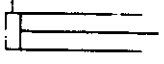

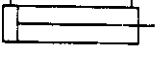
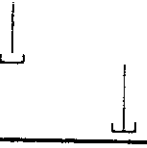
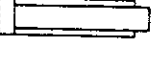
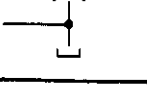
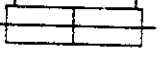

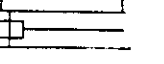
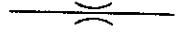
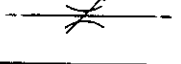





- 5. OVERFLOW VALVE
- 7. AIR RESERVOIR, LARGE
- 8. TEST CONNECTION
- 11. BRAKE BOOSTER
- 12. MASTER CYLINDER
- 20. RELAY VALVE
- 21. GLAD HAND
- 22. GLAD HAND



STANDARD GRAPHICAL SYMBOLS

| LINES AND LINE FUNCTIONS | | PUMPS | |
|---|---|--|---|
| LINE, WORKING |  | PUMP, SINGLE FIXED DISPLACEMENT |  |
| LINE, PILOT (L > 20W) |  | PUMP, SINGLE VARIABLE DISPLACEMENT |  |
| LINE, DRAIN (L < 5W) |  | MOTORS AND CYLINDERS | |
| CONNECTOR |  | MOTOR, ROTARY, FIXED DISPLACEMENT |  |
| LINE, FLEXIBLE |  | MOTOR, ROTARY VARIABLE DISPLACEMENT |  |
| LINE, JOINING |  | MOTOR, OSCILLATING |  |
| LINE, PASSING |  | CYLINDER, SINGLE ACTING |  |
| DIRECTION OF FLOW, HYDRAULIC PNEUMATIC |  | CYLINDER, DOUBLE ACTING |  |
| LINE TO RESERVOIR ABOVE FLUID LEVEL BELOW FLUID LEVEL |  | CYLINDER, DIFFERENTIAL ROD |  |
| LINE TO VENTED MANIFOLD |  | CYLINDER, DOUBLE END ROD |  |
| PLUG OR PLUGGED CONNECTION |  | CYLINDER, CUSHIONS BOTH ENDS |  |
| RESTRICTION FIXED |  | | |
| RESTRICTION, VARIABLE |  | | |

| MISCELLANEOUS UNITS | | BASIC VALVE SYMBOLS (CONT.) | |
|---|--|---|--|
| DIRECTION OF ROTATION (ARROW IN FRONT OF SHAFT) | | VALVE, SINGLE FLOW PATH, NORMALLY OPEN | |
| COMPONENT ENCLOSURE | | VALVE, MAXIMUM PRESSURE (RELIEF) | |
| RESERVOIR, VENTED | | BASIC VALVE SYMBOL, MULTIPLE FLOW PATHS | |
| RESERVOIR, PRESSURIZED | | FLOW PATHS BLOCKED IN CENTER POSITION | |
| PRESSURE GAGE | | MULTIPLE FLOW PATHS (ARROW SHOWS FLOW DIRECTION) | |
| TEMPERATURE GAGE | | VALVE EXAMPLES | |
| FLOW METER (FLOW RATE) | | UNLOADING VALVE, INTERNAL DRAIN, REMOTELY OPERATED | |
| ELECTRIC MOTOR | | DECELERATION VALVE, NORMALLY OPEN | |
| ACCUMULATOR, SPRING LOADED | | SEQUENCE VALVE, DIRECTLY OPERATED, EXTERNALLY DRAINED | |
| ACCUMULATOR, GAS CHARGED | | PRESSURE REDUCING VALVE | |
| FILTER OR STRAINER | | COUNTER BALANCE VALVE WITH INTEGRAL CHECK | |
| HEATER | | TEMPERATURE AND PRESSURE COMPENSATED FLOW CONTROL WITH INTEGRAL CHECK | |
| COOLER | | DIRECTIONAL VALVE, TWO POSITION, THREE CONNECTION | |
| TEMPERATURE CONTROLLER | | DIRECTIONAL VALVE, THREE POSITION, FOUR CONNECTION | |
| INTENSIFIER | | VALVE, INFINITE POSITIONING (INDICATED BY HORIZONTAL BARS) | |
| PRESSURE SWITCH | | | |
| BASIC VALVE SYMBOLS | | | |
| CHECK VALVE | | | |
| MANUAL SHUT OFF VALVE | | | |
| BASIC VALVE ENVELOPE | | | |
| VALVE, SINGLE FLOW PATH, NORMALLY CLOSED | | | |

| METHODS OF OPERATION | | METHODS OF OPERATION | |
|----------------------|---|---|---|
| PRESSURE COMPENSATOR |  | LEVER |  |
| DETENT |  | PILOT PRESSURE |  |
| MANUAL |  | SOLENOID |  |
| MECHANICAL |  | SOLENOID CONTROLLED, PILOT PRESSURE OPERATED |  |
| PEDAL OR TREADLE |  | SPRING |  |
| PUSH BUTTON |  | SERVO |  |

FRONT HYDRAULIC SYSTEM, S.E.E. TRACTOR WHEEL 4X4 DED

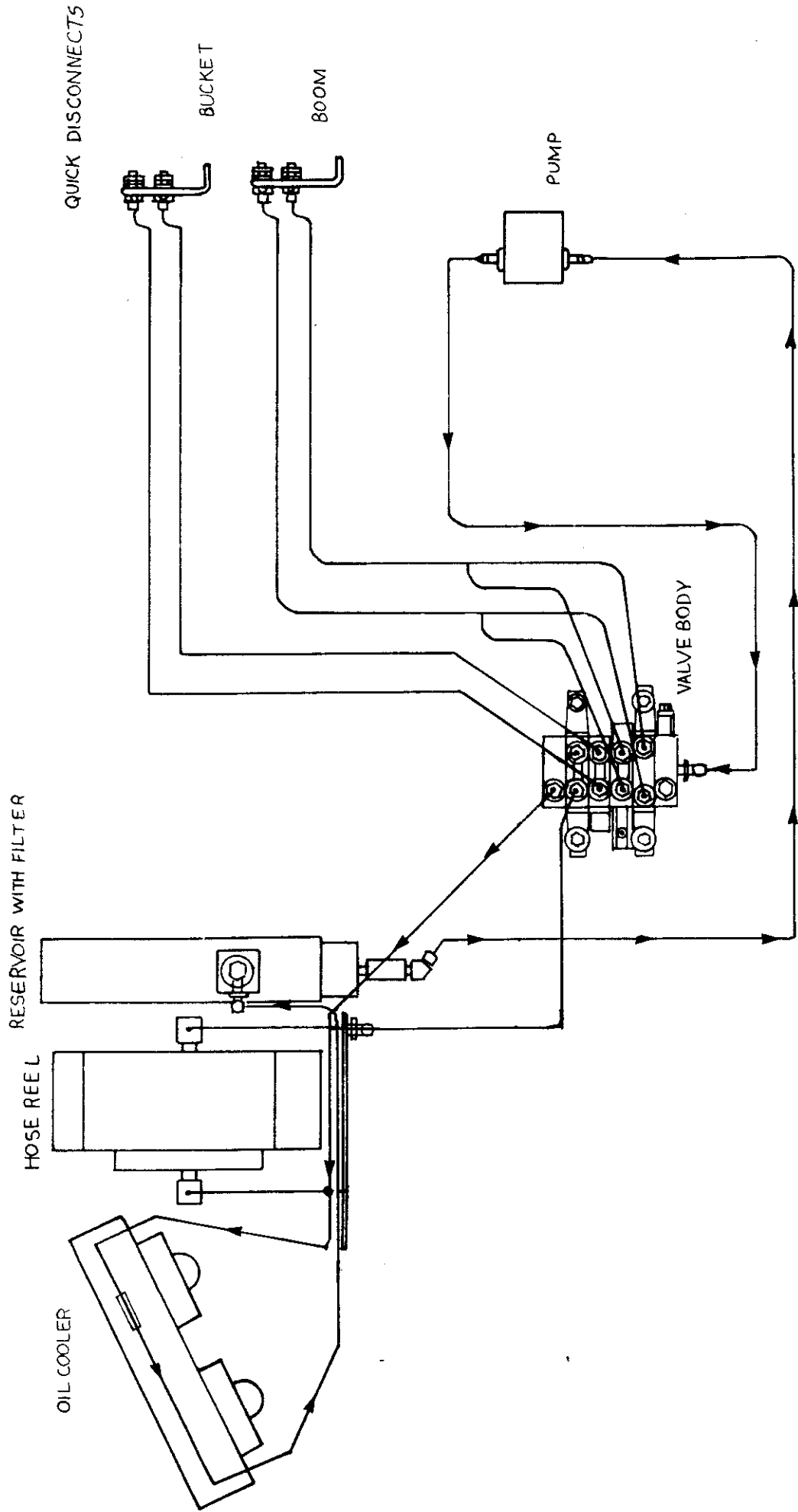

HYDRAULIC DIAGRAM FOR THE FRONT LOADER TYPER FL 4

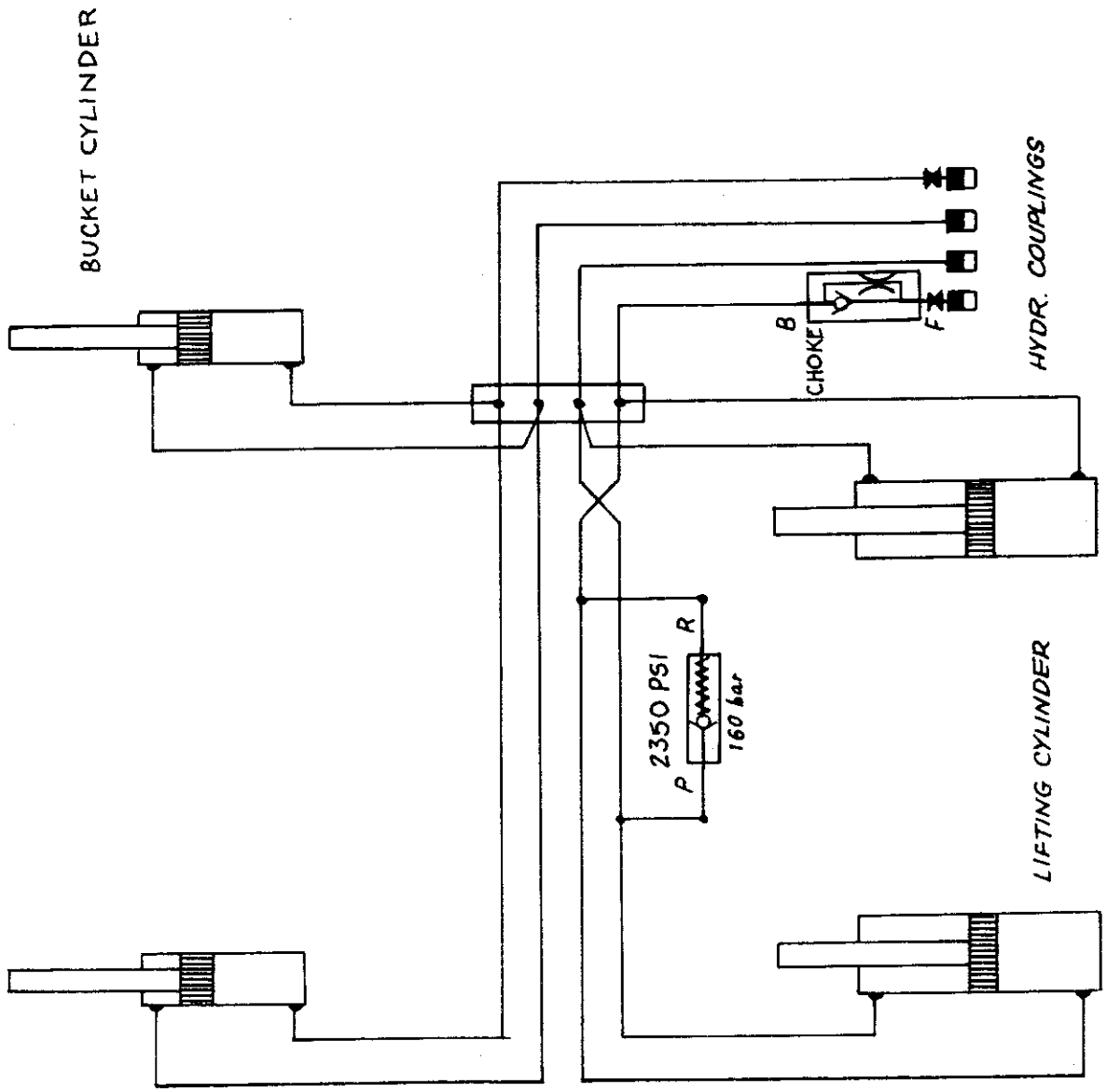

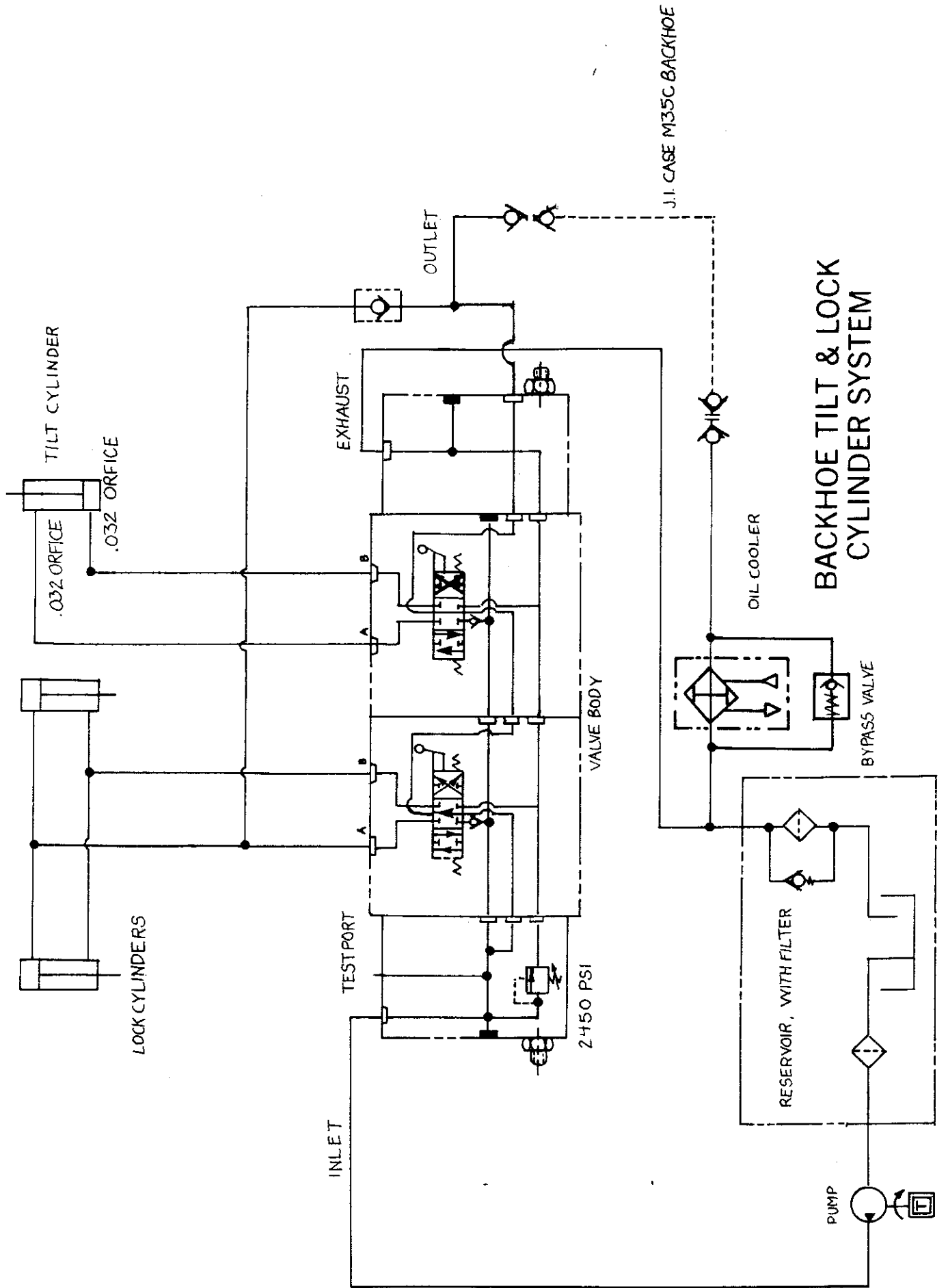

BACKHOE AND STABILIZER SYSTEMS

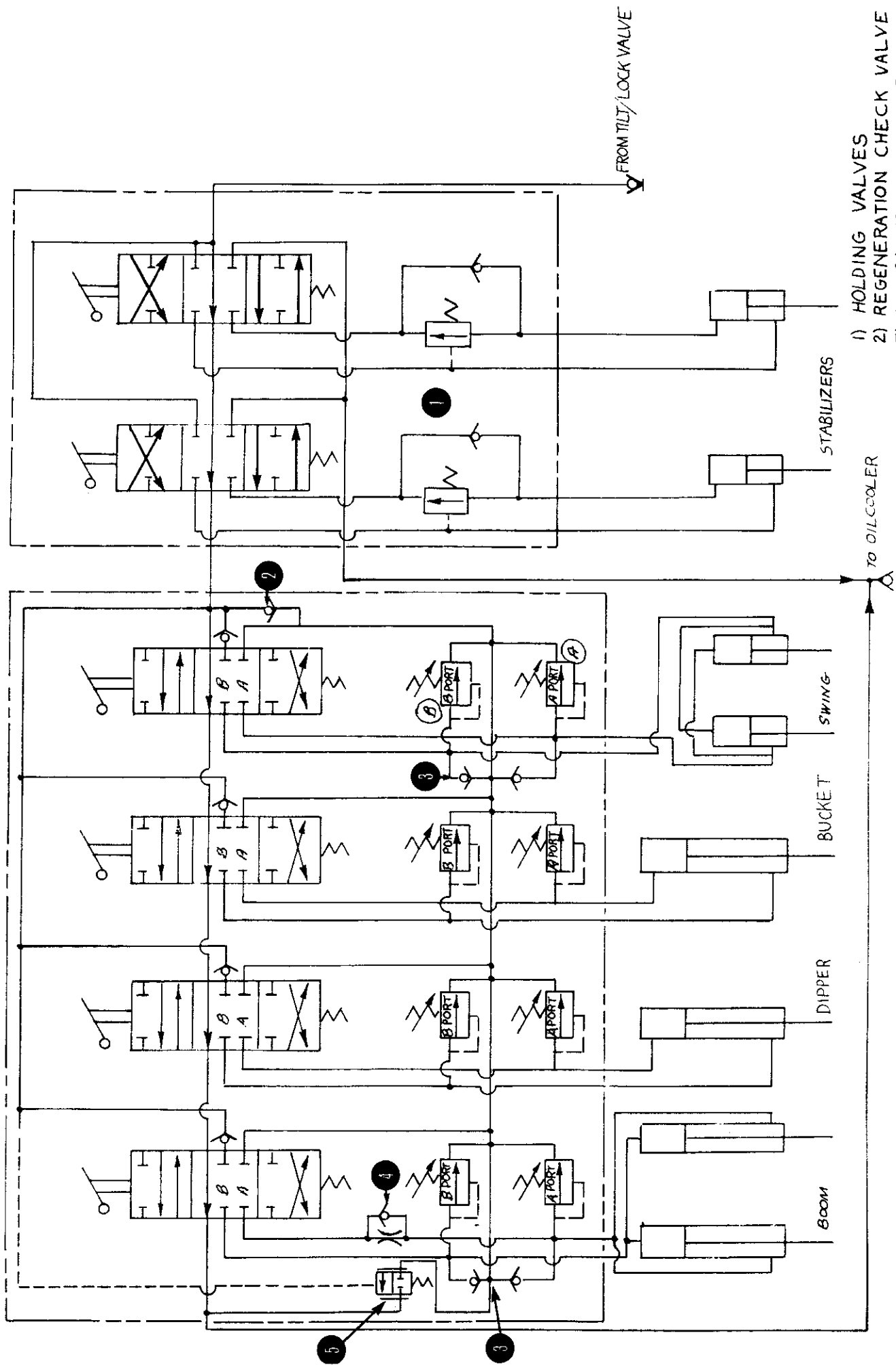

1) HOLDING VALVES

2) REGENERATION CHECK VALVE

3) ANTICAVITATION VALVES

4) FLOW CONTROL VALVE

5) REGENERATION SPOOL (350 PSI)

M35C CASE

BACKHOE CIRCUIT RELIEF PRESSURE

| | | |
|---------------|---------------|---------------|
| <u>BOOM</u> | - A PORT (UP) | 925-1075 PSI |
| | B PORT (DOWN) | 2450-2650 PSI |
| <u>DIPPER</u> | - A PORT | 2450-2650 PSI |
| | B PORT | 2450-2650 PSI |
| <u>BUCKET</u> | - A PORT | 2450-2650 PSI |
| | B PORT | 2450-2650 PSI |
| <u>SWING</u> | - A PORT | 1700-1900 PSI |
| | B PORT | 1700-1900 PSI |

EQUIPMENT DIFFERENCES

SEE Tractor

- Front Loader
- Backhoe
- Chain saw
- Pavement breaker
- Hammer drill

HMMH Tractor

- Suspension lockout system
- Forklift
- Crane
- Impact wrench

EQUIPMENT DATA

Engine

Manufacturer Daimler-Benz
 Model 353.999
 Type 4-stroke diesel, 6 cylinder
 Horsepower 110 (81 kW)

Clutch

Type Single dry plate

Engine Air Cleaner

Manufacturer Donaldson
 Model FSGO9-0160
 Type Dry

Fuel System

Fuel Pump
 Manufacturer Bosch
 Timing @ 700 rpm +50 Low idle
 Injection Order 1-5-3-6-2-4
 Fuel Tank
 Capacity 30 gallons (114 l)

Cooling System

Capacity 6 gallons (23 l)

Electrical System

Batteries

Number 2
 Type Lead-acid
 Voltage 12 vdc
 Connected Series
 Output 24 vdc
 Post to Ground Negative

Alternator

Manufacturer Bosch
 Rating 55 amps
 Drive Belt, by engine

Starter

Manufacturer Bosch

Transmission

Type Fully synchronized
 Speeds 16 forward, 8 reverse
 Power Take-Off Engine driven

B-1

EQUIPMENT DATA (CONT)

Axles
 Type Portal with reduction thrust tubes
 Drive 4-wheel

Suspension
 Springs Coil
 Shock Absorbers Telescopic
 Front Lockout Hydraulic actuated (HMMH)

Brakes
 Service
 Type 4-wheel, dual-circuit disc/caliper
 Power Actuated Hydraulic, air assist
 Warning System Low-air pressure (audible and visual)
 Parking
 Type Caliper, mechanical cable, rear wheels

Air Compressor
 Type Engine driven
 Cylinders 1
 Bore 3.03 inches (77 mm)
 Stroke 1.18 inches (30 mm)
 Capacity @ 2600 rpm 4.77 cfm (135 lpm) @ 105 psi (724 kPa)

Wheels
 Type Interchangeable rim and wheel
 Tires 5 multipurpose
 Size 12.5 R20 12 PR radial
 Pressure Low
 Track Width 64 inches (163 cm)

Steering
 Type Recirculating ball with power assist
 Power Steering Pump Belt, by engine

Hydraulic System
Front (SEE)
 Drive Engine
 Capacity 8 gpm @ 2450 psi (30 lpm @ 167 bar) @ 2000 engine rpm
 Use Front loader and machine tools
Rear (SEE)
 Drive PTO
 Capacity 26 gpm @ 2450 psi (98 lpm @ 167 bar) @ 2000 engine rpm
 Use Backhoe

Front (HMMH)
 Drive Engine
 Capacity 8 gpm @ 2450 psi (30 lpm @ 167 bar) @ 2000 engine rpm
 Use Forklift and impact wrench

Rear (HMMH)
 Drive PTO
 Capacity 14 gpm @ 2450 psi (54 lpm at 167 bar) @ 1100 engine rpm
 Use Crane

B-2

VALVE ADJUSTMENT

This task covers: Adjustment

INITIAL SETUP

Tools and Special Equipment:

Tool Kit, SC 5180-90-CL-N26

Equipment Condition:

Reference

Page 4-3

Condition Description

Valve Cover Removed

ADJUSTMENT

1. Rotate crankshaft to right until rocker arms of No. 6 cylinder overlap. No. 1 cylinder will now be at Top Dead Center (TDC).

CAUTION

Do not make valve adjustments until engine has cooled to below 122°F (50°C) to prevent damage to equipment.

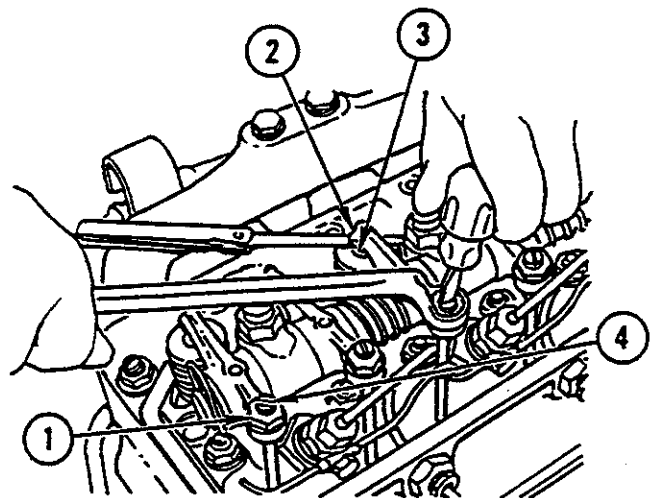

2. Using feeler gage, check valve clearance. Clearance for intake valves 2, 3, and 7 is 0.008 in. (0.20 mm). Clearance for exhaust valves 1, 5, and 9 is 0.012 in. (0.30 mm).
3. If adjustment is required, loosen nut (1) and insert feeler gage between rocker arm (2) and pad (3). Turn adjusting screw (4) until rocker arm just touches feeler gage. Tighten nut (1) and recheck clearance.
4. Rotate crankshaft to right until rocker arms of No. 1 cylinder overlap. No. 6 cylinder will now be at TDC.
5. Repeat steps 2 and 3 for intake valves 6, 10, and 11 and exhaust valves 4, 8, and 12.

NO. 1 CYLINDER AT COMPRESSION TDC

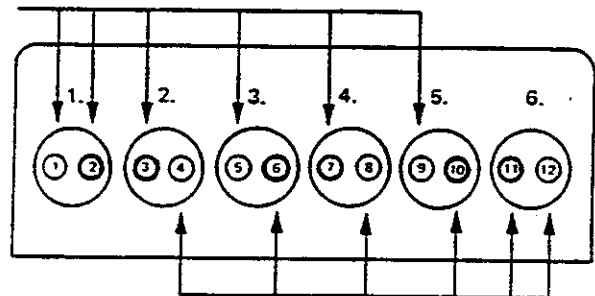

NO. 6 CYLINDER AT COMPRESSION TDC

NOTE

Follow-on Maintenance:
Install valve cover (page 4-3).

B-3

BRAKE SYSTEM BLEEDING

This task covers: Bleeding

INITIAL SETUP

Tools and Special Equipment:

Shop Equipment, SC 4910-95-CL-A74
Tool Kit, SC 5180-90-CL-N26
Elbow (2), P/N 000 589 03 25 00
Hose, P/N 000 589 02 25 00

Materials/Parts:

Fluid, Silicone Brake Appendix C, Item 15
Rags Appendix C, Item 32

Personnel Required: (2)

References:

LO 5-2420-224-12

Equipment Condition:

| Reference | Condition Description |
|------------|-----------------------------|
| Page 4-388 | Outside Engine Hood Removed |

General Safety Instructions:

WARNING
Fuel and oil are slippery and can cause falls. To avoid injury, wipe up spilled fuel or oil with rags.

BLEEDING

CAUTION
Bleeding brake system by pumping brake pedal is not sufficient. Compressed air must be used to bleed brake system to prevent damage to equipment.

1. Remove two brake fluid reservoir caps (1 and 2) from two brake fluid reservoirs (3 and 4).

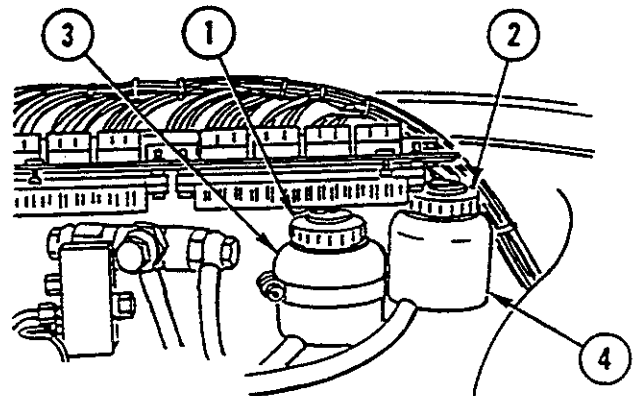

2. Install two elbows on hose.

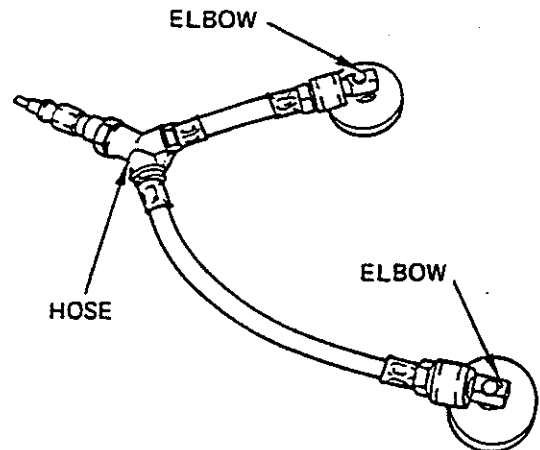

BRAKE SYSTEM BLEEDING (CONT)

3. Install adapter assembly (5) to two brake fluid reservoirs (3 and 4).

CAUTION

Air supply must be regulated to 14.5-29.0 psi (1-2 bar) to prevent damage to equipment.

4. Connect adapter assembly (5) to air supply hose (6).

CAUTION

Brake fluid is to be considered contaminated and is not to be reused to prevent damage to equipment.

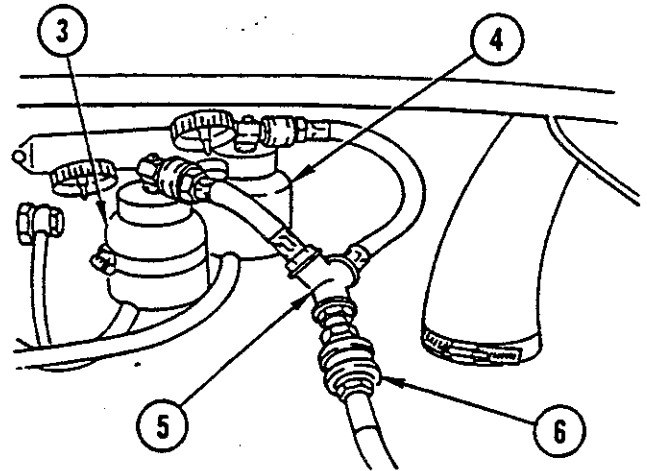

NOTE

- Use suitable container to catch brake fluid.
- Open only one bleeder valve at a time.
- Observe fluid level in brake fluid reservoirs and do not allow brake fluid to go below MIN indication before adding more fluid to reservoir.
- Brake system is considered properly bled when steady stream of brake fluid comes out of bleeder valve with no air bubbles in the stream.

5. Bleed brake system in following order:

- a. Master cylinder (7) 2 places
- b. Right rear caliper (8)
- c. Left rear caliper (9)
- d. Right rear front caliper (10)
- e. Left rear front caliper (11)
- f. ALB modulator (12)
- g. Right front caliper (13)
- h. Left front caliper (14)
- i. Clutch slave cylinder (15)

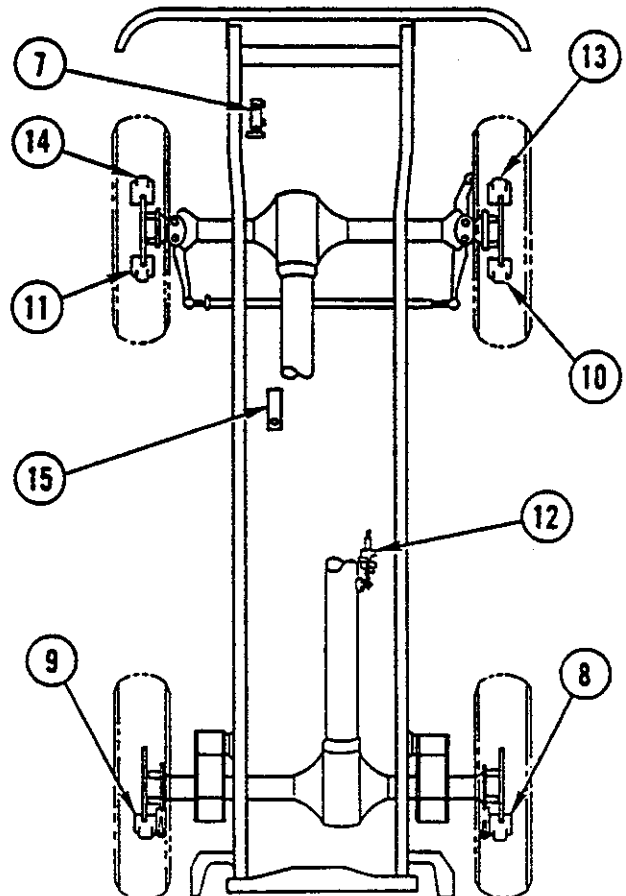

B-5

BRAKE SYSTEM BLEEDING (CONT)

6. Disconnect air supply hose (6) from adapter assembly (5).
7. Remove adapter assembly (5) from two brake fluid reservoirs (3 and 4).

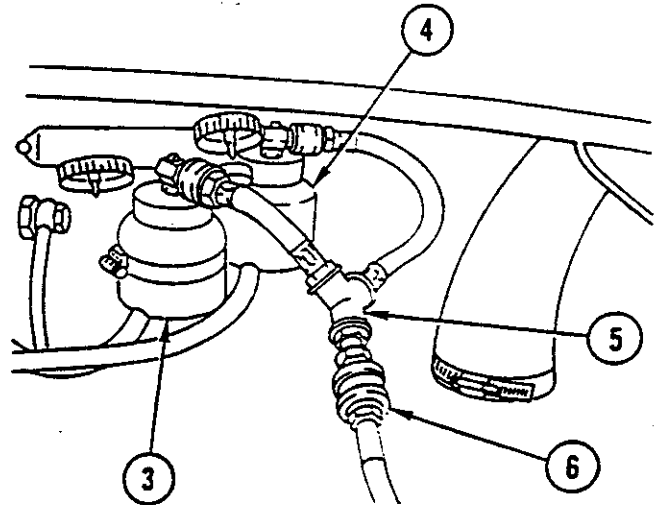

8. Remove two elbows from hose.
9. Fill two brake fluid reservoirs (3 and 4) to MAX level with brake fluid.

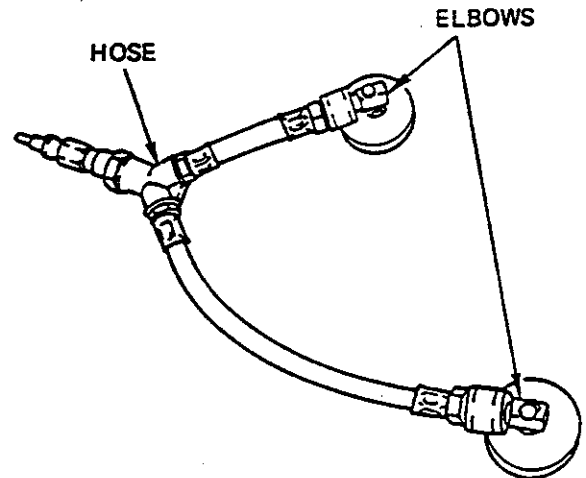

10. Install two brake fluid reservoir caps (1 and 2) on two brake fluid reservoirs (3 and 4).

NOTE

Follow-on Maintenance:

Fill clutch hydraulic reservoir (LO 5-2420-224-12).

Fill brake fluid reservoir (LO 5-2420-224-12).

Install outside engine hood (page 4-388).

